



*Fisher Engineering*

July 1997  
No. 21856



## **MECHANIC'S GUIDE**

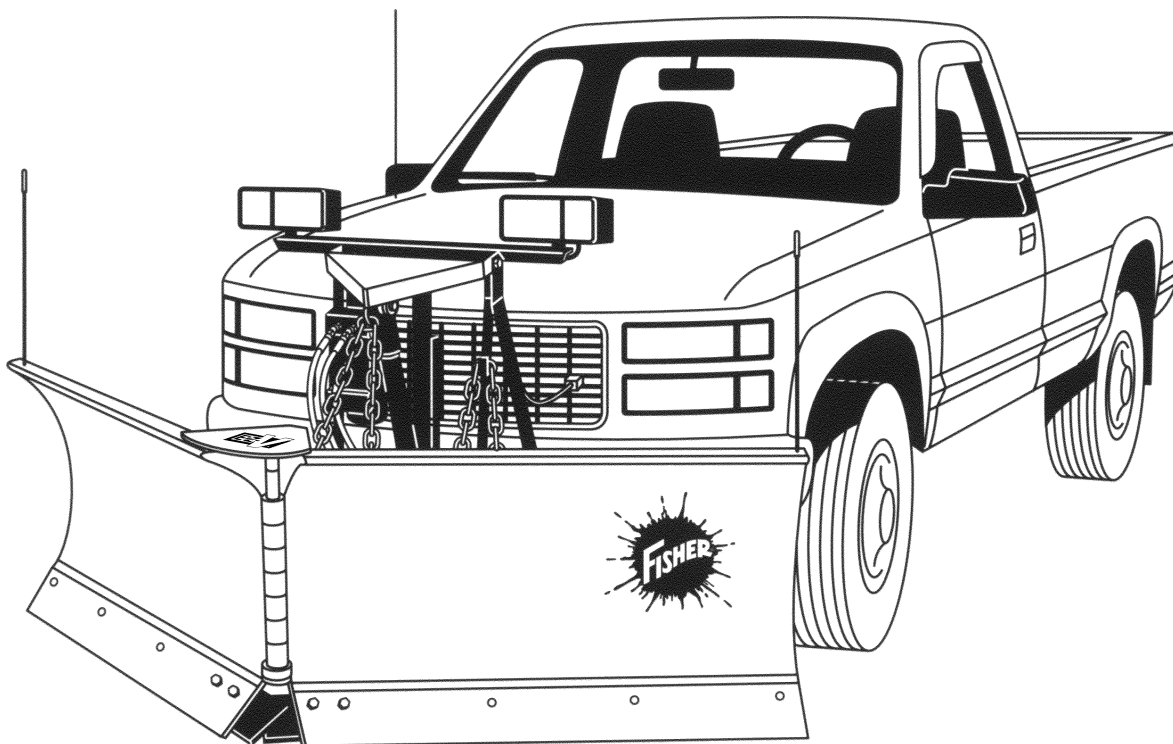

**CAUTION:** Read this manual before servicing the FISHER® EZ-V™ snowplow.

## TABLE OF CONTENTS

## PREFACE

Preface .....	2
Safety Information .....	3
Tools Required .....	5
Product Specifications .....	5
Hose Routing .....	6
Hydraulic Unit Parts Diagram .....	7
Solenoid Cartridge Valve Identification and Location .....	8
Relief Valve Identification and Location .....	9
Pilot Operated Check Valve Identification and Location .....	10
Vehicle Harness and Vehicle Cable Location .....	11
Operating the Snowplow .....	12
Theory of Operation .....	15
Hydraulic and Electrical Schematics .....	17
Electrical Schematic .....	18
Hydraulic Schematic .....	19
Angle Right .....	20
Angle Left .....	22
Right Retract .....	24
Right Extend .....	26
Left Retract .....	28
Left Extend .....	30
Scoop .....	32
Vee .....	34
Raise .....	36
Lower .....	38
Hold in Raise Position – Hydraulic .....	40
Striking an Object While Plowing Forward – Hydraulic .....	41
Striking An Object While Back Dragging – Hydraulic .....	42
Headlamps – Vehicle Only .....	43
High Beam Headlamps With Plow Connected to Vehicle .....	44
Low Beam Headlamps With Plow Connected to Vehicle .....	45
Troubleshooting Guide .....	46
Removable Spring Tool .....	70

This guide has been prepared to assist the trained mechanic in the service of FISHER® snowplows. It also provides safety information and recommendations. We urge all mechanics to read this manual carefully before attempting to service the FISHER snowplow equipment covered by this guide.

Service of your FISHER snowplow equipment is best performed by your local Fisher outlet. They know your snowplow best and are interested in your complete satisfaction.

# SAFETY INFORMATION

## ⚠ WARNING

Indicates a potentially hazardous situation that, if not avoided, could result in death or serious personal injury .

## ⚠ CAUTION

Indicates a situation that, if not avoided, could result in minor personal injury and/or damage to product or property.

**NOTE:** Identifies tips, helpful hints and maintenance information the owner/operator should know.

## BEFORE YOU BEGIN

## ⚠ WARNING

Lower blade when vehicle is parked. Temperature changes could change hydraulic pressure, causing the blade to drop unexpectedly or damaging hydraulic components. Failure to do this can result in serious personal injury.

## ⚠ WARNING

Remove blade assembly before placing vehicle on hoist. Failure to do this could result in personal injury.

## ⚠ WARNING

Do not exceed GVWR or GAWR (including blade and ballast) as found on the driver-side door cornerpost of the vehicle.

- Park the vehicle on a level surface, place shift lever in PARK or NEUTRAL and set parking brake.
- Leave the snowplow mounted on the vehicle and lowered for most service procedures, unless told otherwise.

## PERSONAL SAFETY

- Wear only snug-fitting clothing while working on your vehicle or snowplow.
- Do not wear jewelry or a necktie, and secure long hair.
- Be especially careful near moving parts such as fan blades, pulleys and belts.
- Wear safety goggles to protect your eyes from battery acid, gasoline, dirt and dust.
- Avoid touching hot surfaces such as the engine, radiator, hoses and exhaust pipes.
- Always have a fire extinguisher rated BC, for flammable liquids and electrical fires, handy.

## VENTILATION

## ⚠ WARNING

Vehicle exhaust contains deadly carbon monoxide (CO) gas. Breathing this gas, even in low concentrations, could cause death. Never operate a vehicle in an enclosed area without venting exhaust to the outside.

If you work on the vehicle or snowplow in a garage or other enclosed area, be sure to vent exhaust gas directly to the outside through a leakproof exhaust hose.

## FIRE AND EXPLOSION

## ⚠ WARNING

Gasoline is highly flammable and gasoline vapor is explosive. Never smoke while working on vehicle. Keep all open flames away from gasoline tank and lines. Wipe up any spilled gasoline immediately.

Be careful when using gasoline. Do not use gasoline to clean parts. Store only in approved containers away from sources of heat or flame.

## HYDRAULIC SAFETY

## ⚠ WARNING

Hydraulic oil under pressure could cause skin injection injury. If you are injured by hydraulic oil, get medical treatment immediately.

- Always inspect hydraulic components and hoses before using. Replace any damaged or worn parts immediately.
- If you suspect a hose leak, DO NOT use your hand to locate it. Use a piece of cardboard or wood.

# SAFETY INFORMATION

## BATTERY SAFETY

### ⚠ CAUTION

Batteries normally produce explosive gases which can cause personal injury. Therefore, do not allow flames, sparks or lit tobacco to come near the battery. When charging or working near a battery, always cover your face and protect your eyes, and also provide ventilation.

Batteries contain sulfuric acid which burns skin, eyes and clothing.

Disconnect the battery before removing or replacing any electrical components.

Please become familiar with the Safety and Instruction labels on the back of the blade!

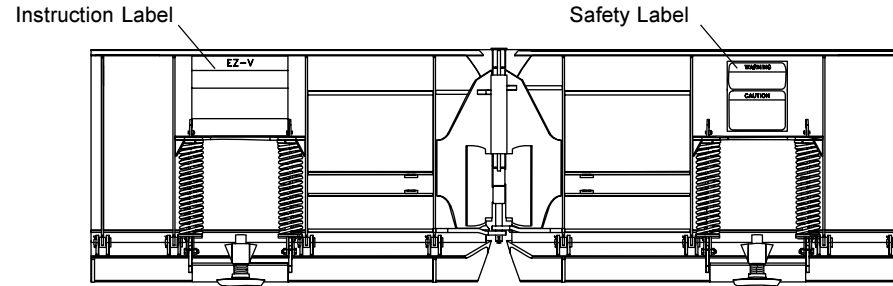





### Instruction Label

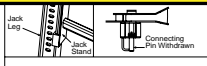

U.S. Patent  
4,280,052; 4,569,935  
5,353,530; 5,420,460  
and other patents pending.

**MOUNTING PLOW**

1. Drive vehicle forward fully engaging pushplates into attachment arms.
2. Twist connecting pin to release tension.
3. Remove electrical covers on vehicle.
4. Attach electrical connector to corresponding connector on vehicle.
5. Repeat these steps on passenger side of vehicle.
6. Release carrying chain and reattach it leaving plenty of slack.
7. Push headgear upward toward vehicle until connecting pins snap in place.
8. Pull jack lever outward and raise the jack leg.

**PLOW REMOVAL**

9. Remove slack from carrying chain and reattach.
10. Back vehicle away from plow.
1. Position blade in the "straight" mode before removing.
2. Place control in "Lower" mode.
3. Push lift arm down.
4. Pull jack lever outward. Jack leg will adjust to proper height.
5. Disconnect electrical connectors and cover with protective covers.
6. Insert release rod in lowest possible slot on jack leg above A-frame.
7. Push down on release rod as you pull and twist connecting pin.
8. Repeat these steps on passenger side of vehicle.

21793

### Safety Label

**⚠ WARNING**

LOWER BLADE WHEN VEHICLE IS PARKED.

REMOVE BLADE ASSEMBLY BEFORE PLACING VEHICLE ON HOIST.

DO NOT EXCEED GVWR OR GAWR INCLUDING BLADE AND BALLAST.

---

**⚠ CAUTION**

READ OWNER'S MANUAL BEFORE OPERATING OR SERVICING SNOWPLOW.

TRANSPORT SPEED SHOULD NOT EXCEED 45 MPH. REDUCE SPEED UNDER ADVERSE TRAVEL CONDITIONS.

PLOWING SPEED SHOULD NOT EXCEED 10 MPH.

REMOVE SLACK FROM CARRYING CHAIN BEFORE TRAVELING.

SEE YOUR FISHER OUTLET FOR APPLICATION RECOMMENDATIONS.

21793

## TOOLS REQUIRED

## PRODUCT SPECIFICATIONS

### Tools

For servicing the electrical and hydraulic system

Required:

- Miniature Needle Nose Pliers
- Flat Screwdriver
- Combination Wrenches: 3/8", 7/16" (2), 1/2", 11/16", 3/4", 7/8"
- 1/4" Socket or Nut driver
- Test Light

Recommended :

- Combination Wrenches: 1-1/16", 1-1/8"
- Deep Sockets: 11/16", 7/8", 1-1/16", 1-1/8"
- Torque Wrench ( IN-LB )
- Volt/Ohm Meter
- Pencil Magnet
- 3000 PSI Pressure Gauge

For replacing trip springs :

- Removable Spring Tool — available from your Fisher outlet

### V-Plow Specifications

#### Hydraulic System

Relief valve settings

- Pump relief valve = 1750 PSI. 2 1/2 - 2 3/4 turns CCW from fully seated
- Primary relief valve = 3000 PSI. 1 1/2 - 1 3/4 turns CCW from fully seated
- Secondary relief valve = 3500 PSI. 1 1/4 - 1 1/2 turns CCW from fully seated

Fluid Capacity—Hydraulic Oil

- Unit Reservoir = 1 3/4 Quarts
- System Total = 2 1/2 Quarts

Hydraulic Oil

#### **⚠ CAUTION**

**Do not mix different types of hydraulic fluid. Some fluids are not compatible and may cause performance problems and product damage.**

- FISHER® High Performance Fluid to -25°F (-32°C)

Solenoid Valve Spool Travel = 0.07" for three- and four-way valves

#### Electrical System – approximate values:

- Solenoid Coil Resistance = 7 Ohms at room temperature
- Solenoid Coil Amp. Draw = 1.5 Amp.
- Motor Relay Coil Resistance = 16 - 17 Ohms
- Motor Relay Amp. Draw = 0.7 Amp.
- Maximum Motor Amp. Draw = 190 Amp.
- Headlamp Relay Coil Resistance = 106 Ohms
- Headlamp Relay Amp Draw = 0.1 Amp.

Fuse Size

- Harness – 10 Amp. (10AFB 3AG)
- Circuit Board (2) – 5 Amp. (5AFB SMD)

#### Mechanical

Fastener Torque for :

- Pump Bolts = 150–160 IN-LB
- Motor Bolts = 30–40 IN-LB
- Reservoir Bolts = 15–20 IN-LB
- Cartridge Torque = 120 IN-LB
- Check Valve Torque = 120 IN-LB
- Coil Nut Torque = 48–60 IN-LB
- Secondary Manifold Block Assembly Bolt Torque = 108 IN-LB
- Angle Cylinder  
Piston Locknut Torque = 100-120 FT-LB  
Gland Nut Torque = 150-180 FT-LB.

# HOSE ROUTING

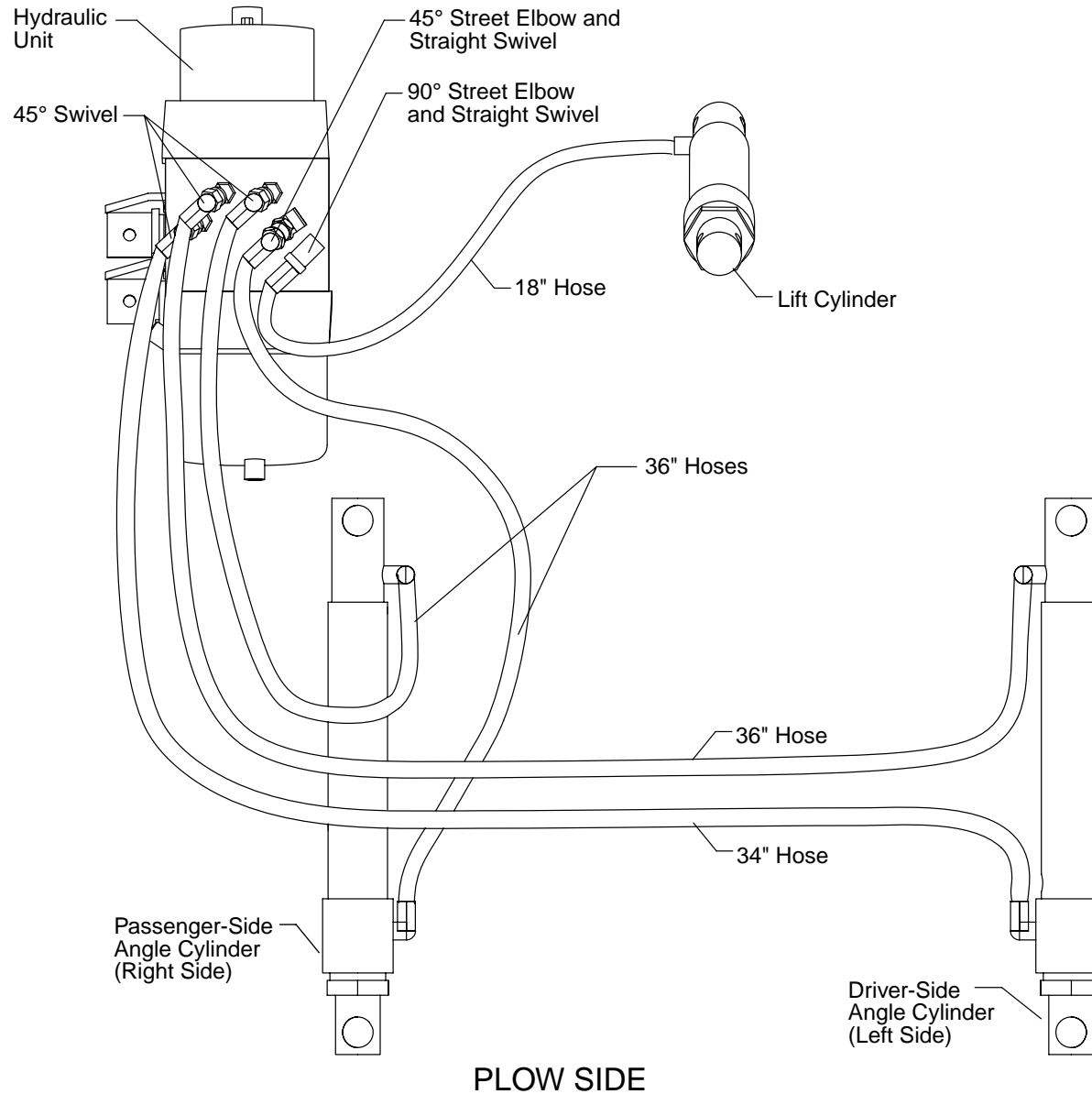

# HYDRAULIC UNIT PARTS DIAGRAM

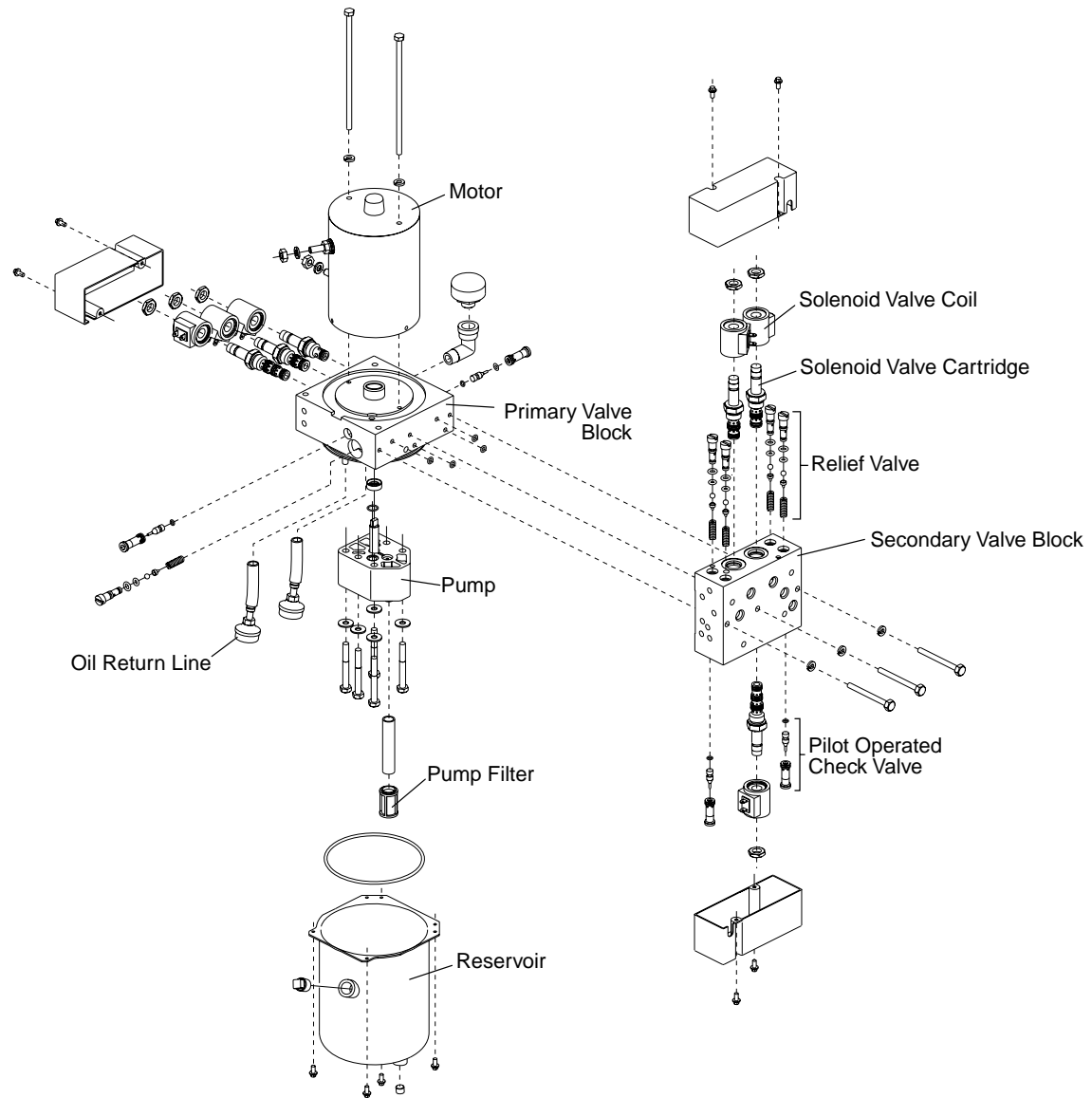

# SOLENOID CARTRIDGE VALVE IDENTIFICATION AND LOCATION

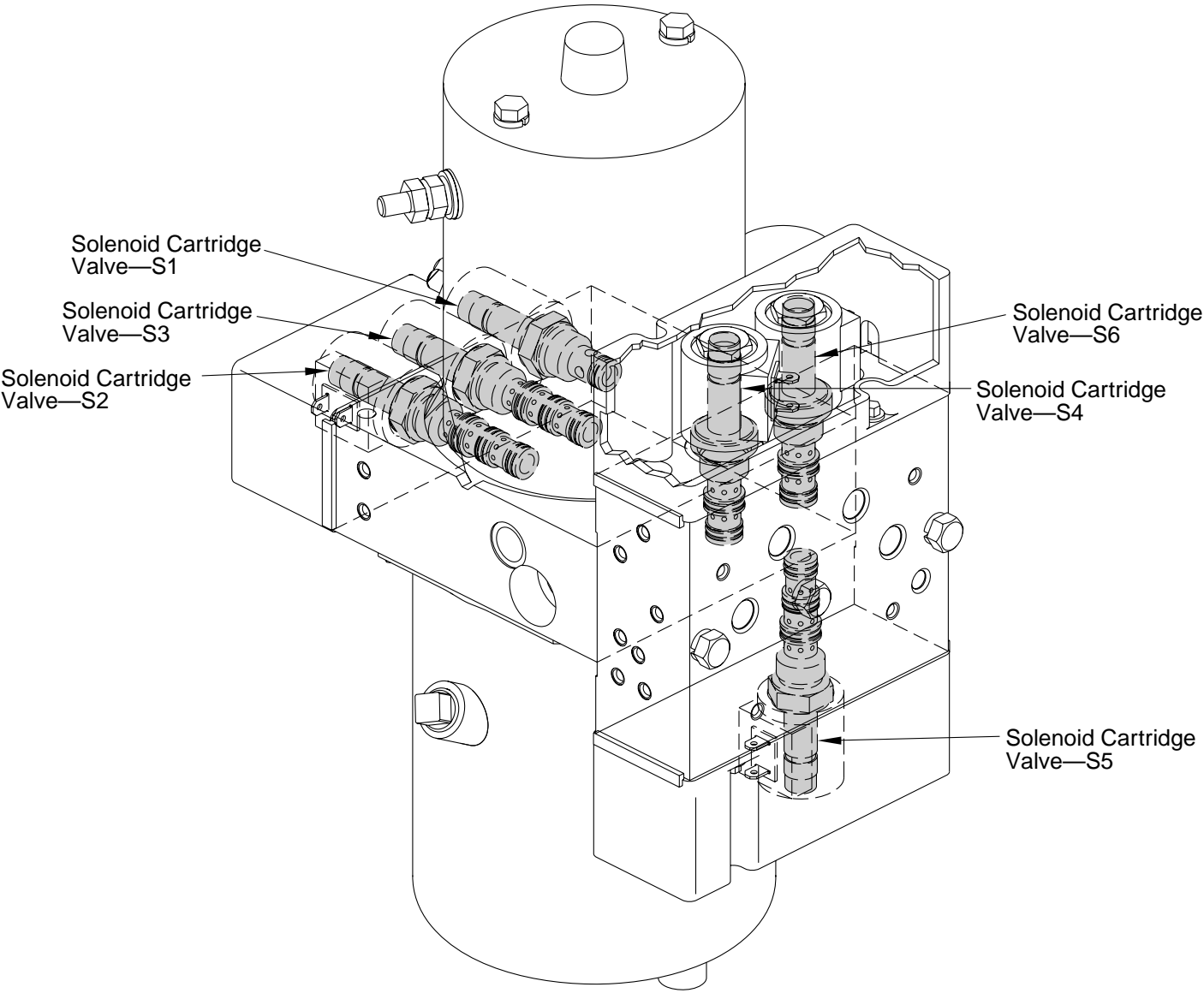



# RELIEF VALVE IDENTIFICATION AND LOCATION

---

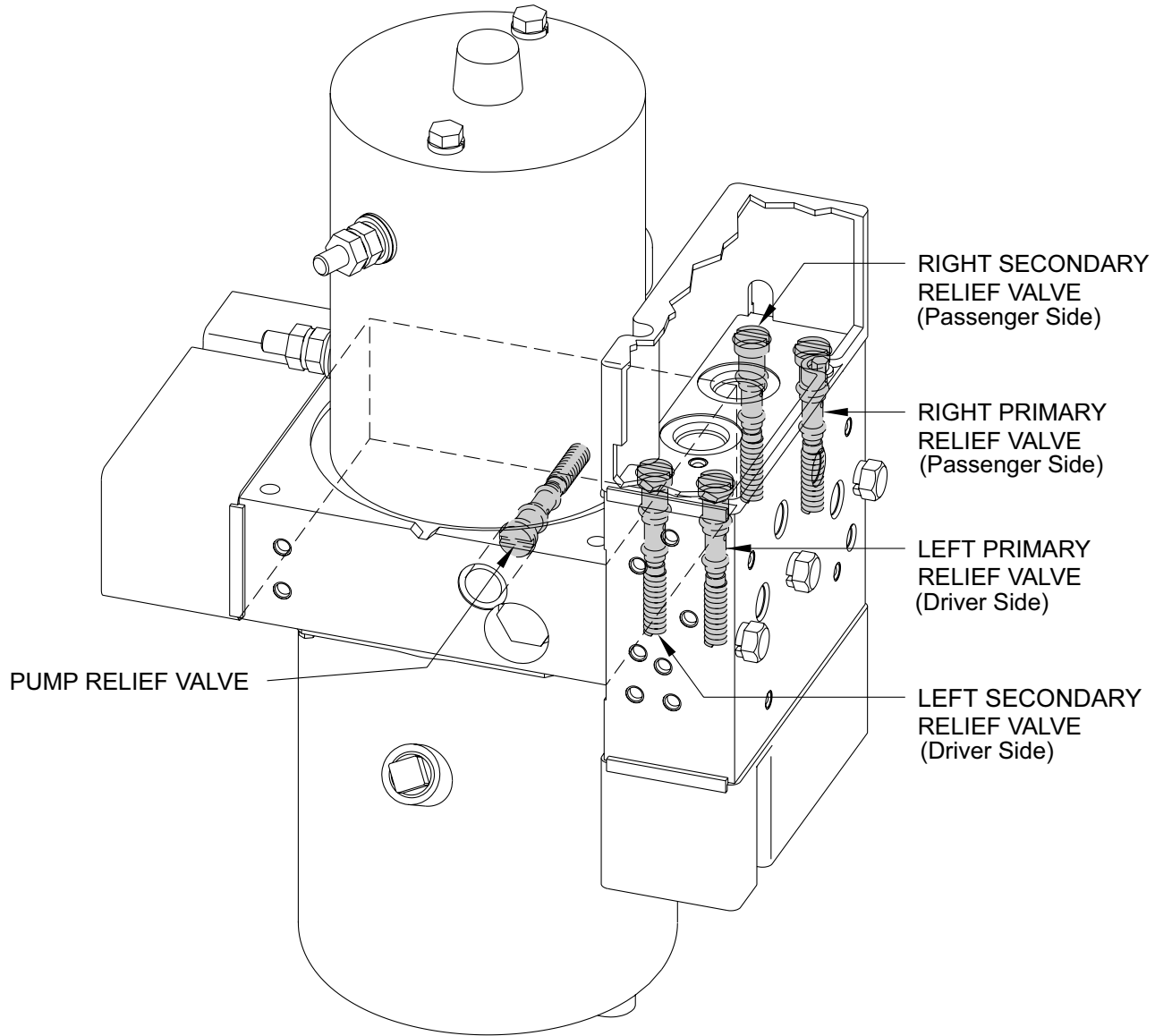

# PILOT OPERATED CHECK VALVE IDENTIFICATION AND LOCATION

---

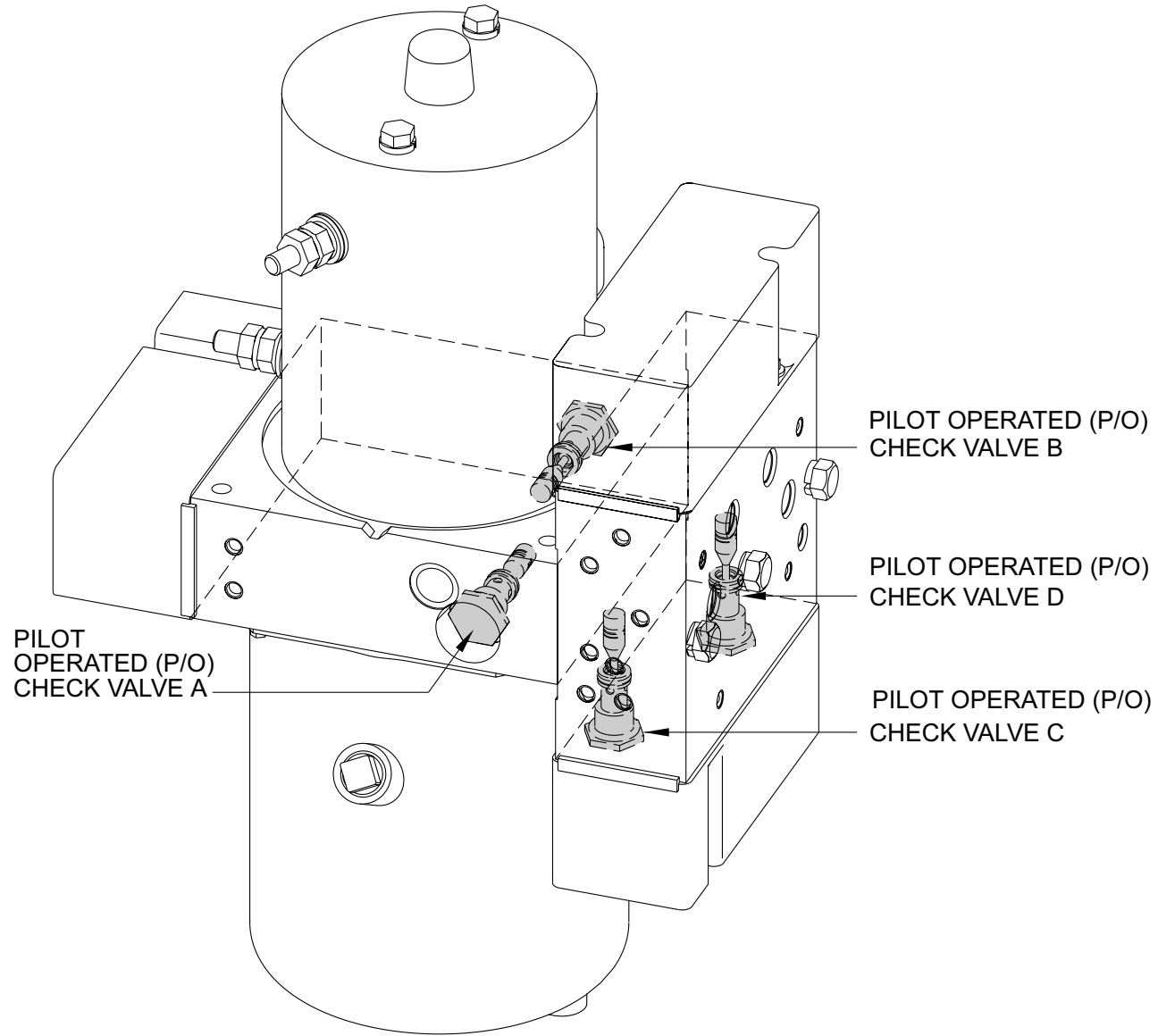

# VEHICLE HARNESS AND VEHICLE CABLE LOCATION

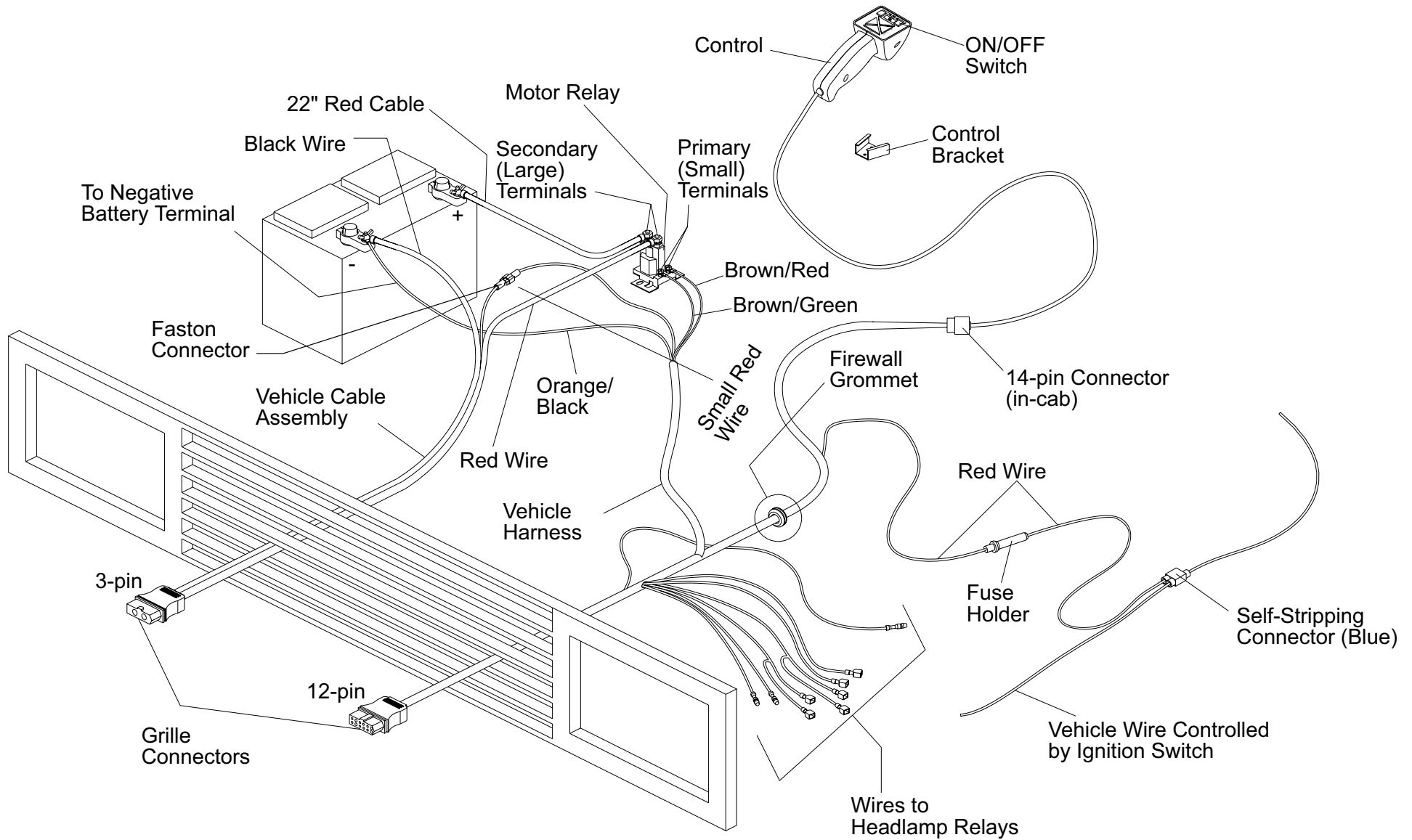

# OPERATING THE SNOWPLOW

## Fish-Stik™ Hand-Held Control

### ⚠ WARNING

The driver shall keep bystanders clear of the blade when it is being raised, lowered or angled. Do not stand between the vehicle and the blade, or within 8 feet of a moving blade. A moving or falling blade could cause personal injury.

### ⚠ CAUTION

To prevent accidental movement of the blade, always turn the ON/OFF switch to OFF whenever the snowplow is not in use. The control indicator light will turn off.

1. Turn the vehicle ignition switch to the ON or the ACCESSORY position.

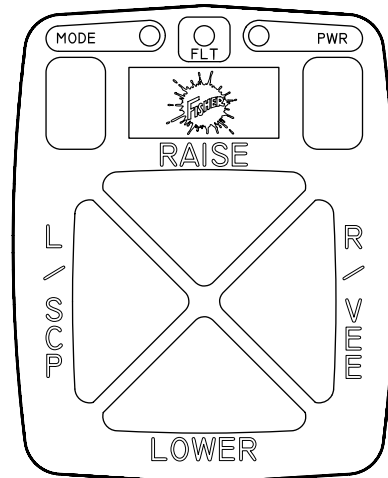

2. Press the PWR button on the control. The control indicator light will glow red indicating the control is on. The control indicator light will glow red whenever the control ON/OFF switch and the vehicle ignition switch are both ON and the plow plugs are connected to the grill connectors.

## Function Time Outs

All control functions, except for LOWER, automatically time out—stop—after a period of time. This is to help prolong the battery charge. The time-out period for the RAISE function is 2.5 seconds, while all others are 4.25 seconds.

The control will automatically turn off after being idle for 20 minutes.

## Smooth Stop

The control automatically allows the blade to coast to a stop. This results in smoother operation, reduces the shock to the hydraulic system and increases hose and valve life.

# OPERATING THE SNOWPLOW

---

## Straight Blade Mode—Default

The control automatically defaults to the straight blade mode when turned on. The MODE lamp, near the MODE key in the upper left corner of the keypad, will not be illuminated or flashing when the control is in the straight blade mode.

The functions shown at right are performed in the straight blade mode:

Button	Description of Operation
Raise	Press this button to raise the plow and to cancel the float mode. NOTE: Plow will automatically stop raising after 2.5 seconds. To resume raising the plow, release the button and press again.
Lower	Press this button to lower the plow. NOTE: After reaching the desired height, release the button. Holding the button down for more than 3/4 second will activate the float mode, indicated by green FLT lamp.
L / SCP	Press this button to angle both wings to the left.
R / VEE	Press this button to angle both wings to the right.

## Vee/Scoop Mode

Quickly press and release the MODE key to put the control into the vee/scoop mode. The MODE lamp, near the upper left corner of the keypad, will light. Quickly pressing and releasing the MODE key will toggle the control between straight blade mode and vee/scoop mode.

The functions shown at right are performed in the vee/scoop mode:

Button	Description of Operation
Raise	Press this button to raise the plow and to cancel the float mode. NOTE: Plow will automatically stop raising after 2.5 seconds. To resume raising the plow, release the button and press again.
Lower	Press this button to lower the plow. NOTE: After reaching the desired height, release the button. Holding the button down for more than 3/4 second will activate the float mode, indicated by green FLT lamp.
L / SCP	Press this button to extend both wings to the scoop position.
R / VEE	Press this button to retract both wings to the vee position.

# OPERATING THE SNOWPLOW

---

## Wing Mode

To put the control into the wing mode, press and hold the MODE key for about two seconds until the MODE lamp near the upper left corner of the keypad is flashing. The L / SCP and R / VEE keys are used to activate the four functions of the wing mode. The RAISE and LOWER keys function the same as in the other modes.

The functions shown at right are performed in the wing mode:

Button	Description of Operation
Raise	Press this button to raise the plow and to cancel the float mode. NOTE: Plow will automatically stop raising after 2.5 seconds. To resume raising the plow, release the button and press again.
Lower	Press this button to lower the plow. NOTE: After reaching the desired height, release the button. Holding the button down for more than 3/4 second will activate the float mode, indicated by green FLT lamp.
L / SCP	Pressing this button the first time will retract the left wing. Pressing this button the next time will extend the left wing.
R / VEE	Pressing this button the first time will retract the right wing. Pressing this button the next time will extend the right wing.

# THEORY OF OPERATION

## Plow Hydraulics

The EZ-V™ snowplow hydraulic system performs 10 blade movement functions.

All functions require the vehicle ignition (key) switch to be in the run or accessory position and the power to be activated on the snowplow cab control.

Nine of the ten hydraulic functions require energizing the electric motor, shifting of solenoid cartridge spools or activating p/o check valves. The tenth function, lower, does not energize the motor but requires shifting of solenoid cartridge spools.

### Operation of Electrical Circuit:









The electrical drive circuit that is used for the EZ-V snowplow hydraulics is defined as a *low side drive* system.

Low side drive provides a common live hot (12V) to all of the loads (coils, relays, etc.). When the cab control is activated, the ground path is closed to complete the circuit, energizing the selected coils and/or relay. The current flow through the coils produces a magnetic field which shifts the spools in the cartridges. The cartridges direct the fluid flow to the appropriate passages to produce the selected blade movement function. Current flow also energizes the motor relay, closing the motor relay contacts connecting the motor to the battery through heavy electrical cables. The heavy cables carry a

large current flow which energizes the motor, which in-turn rotates the internal pump and creates fluid flow. (Motor relay does not energize in “lower” function).

### Testing Low Side Drive Systems:

To test a low side drive system, connect the negative lead of the test instrument (volt meter) to ground and the positive lead to the negative side of the load (coil, relay, etc.). A reading of 12 volts should be indicated when the load is not activated. A reading of near 0 volts when load is activated.

CONTROLLER MODE	STRAIGHT BLADE (DEFAULT)		WING				V / SCOOP		ALL	ALL
CONTROLLER BUTTON	R/VEE	L/SCP	R/VEE *	R/VEE *	L/SCP *	L/SCP *	L/SCP	R/VEE	RAISE	LOWER
<b>BLADE MOVEMENT</b>	ANGLE RIGHT 	ANGLE LEFT 	RIGHT RETRACT 	RIGHT EXTEND 	LEFT RETRACT 	LEFT EXTEND 	SCOOP 	VEE 	RAISE	LOWER

# THEORY OF OPERATION

---

## Plow Headlamps

The headlamp circuit operates using a high side drive system. High side drive provides a hot 12V source to activate the loads (coils, relays, etc.) that share a common ground. The headlamp switching circuit uses two single pole double throw (SPDT) relays. When combined with the snowplow plug-in headlamp harness and the vehicle harness, the relays will automatically switch between plow and vehicle headlamps as the plow plugs are connected and disconnected.

The vehicle harness has a brown wire that is spliced into the vehicle park lamp circuit. This wire feeds the plow park lamps through the grill connector and also powers the coils

of both relays. The other terminal of the relay coils is connected to the black/orange ground wire which also goes to the grill connector. When both the plow and battery cable plugs are connected to the grill connectors, a ground is completed for the relay coil. When the vehicle park lamps are turned on and the plugs are connected, the relay coils will be activated. This causes the relay contacts to switch from the normally closed contacts to the normally open contacts. The normally closed contacts power the vehicle headlamps. The normally open contacts power the plow headlamps.

Refer to the Headlamp Test Diagram in the Troubleshooting Guide.

It should be noted that:

- The relay with the yellow, orange and black wires operates the low beam headlamps.
- The relay with the green, red and white wires operates the high beam headlamps.
- The parking lamp circuit provides power to both relays at the same time.
- Both plow plugs (12 pin and battery cable) need to be connected and the headlamp switch must be on for the relays to activate.

## Daytime Running Lights

An additional fused pink wire is used in place of the brown park circuit wire to introduce power to the light relays. The pink wire is connected to a circuit controlled by the vehicle ignition switch. When the vehicle ignition is on and the grill connector plugs are connected the relay coils will be activated. This allows the DRLs to be switched to the plow lights when the vehicle headlamp switch is off. DRLs use the same circuit as the regular headlamps.

## Testing High Side Drive Systems:

Connect the negative lead of the test instrument (voltmeter) to ground and positive lead to the positive side of the load. A reading of 12 volts should be indicated when the load is activated; zero volts when load is not activated.

16



# HYDRAULIC AND ELECTRICAL SCHEMATICS

The following section contains hydraulic and electrical schematics to help explain how the hydraulic unit performs the different functions. A schematic is an abstract drawing showing the purpose of each of the components in the system. Each component is represented by a graphical symbol. The hydraulic and electrical legends list and describe each of the symbols used in the schematics for this guide.

The first two schematics show a general overview of the complete hydraulic and electrical systems. The remainder of the schematics have been altered to highlight flow of hydraulic oil and electrical current for each function the hydraulic unit performs or flow of electrical current for the snowplow and vehicle lights.

- Bold lines represent the circuit being activated only.
- Shaded components are either activated or shifted from their normal position.

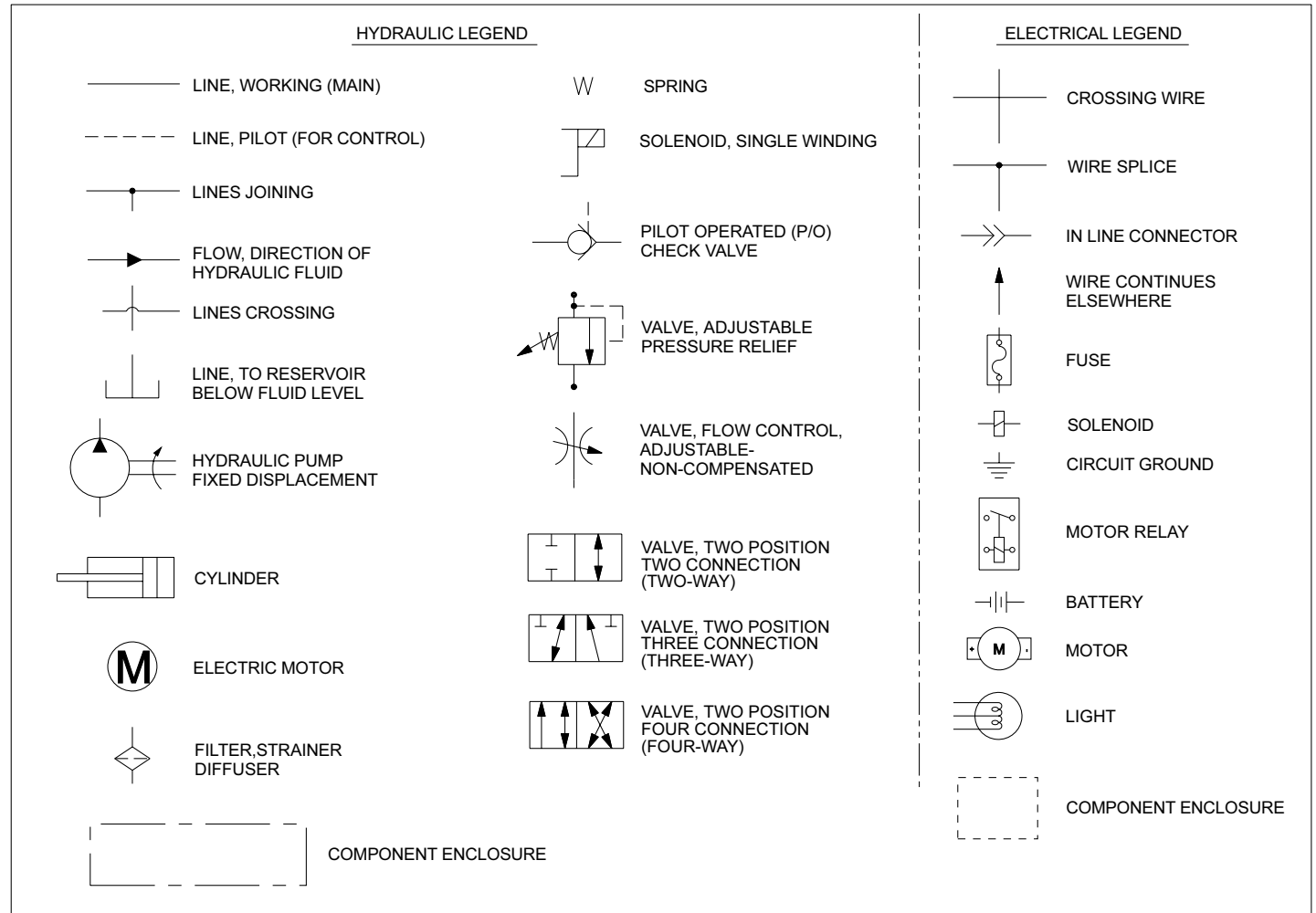



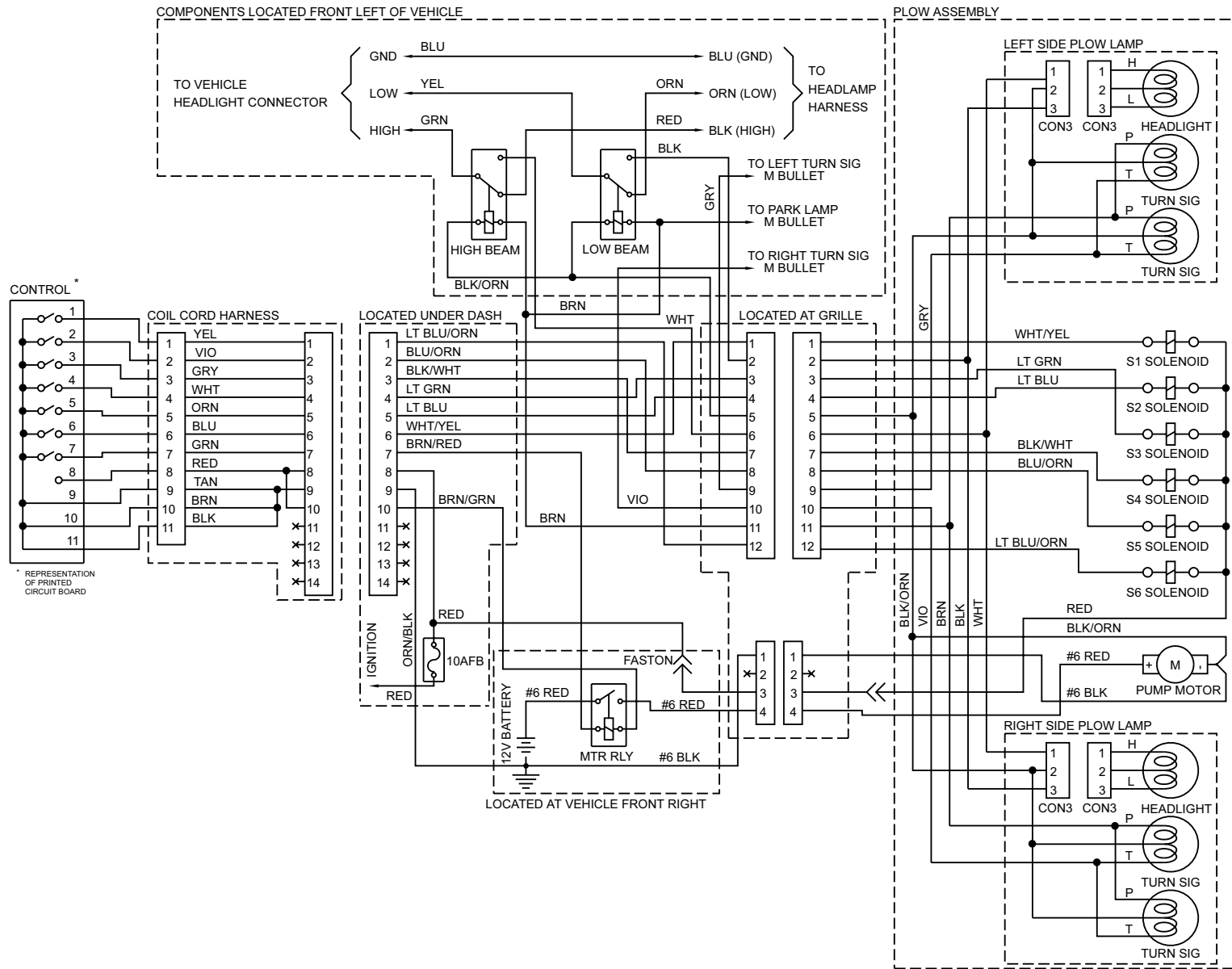



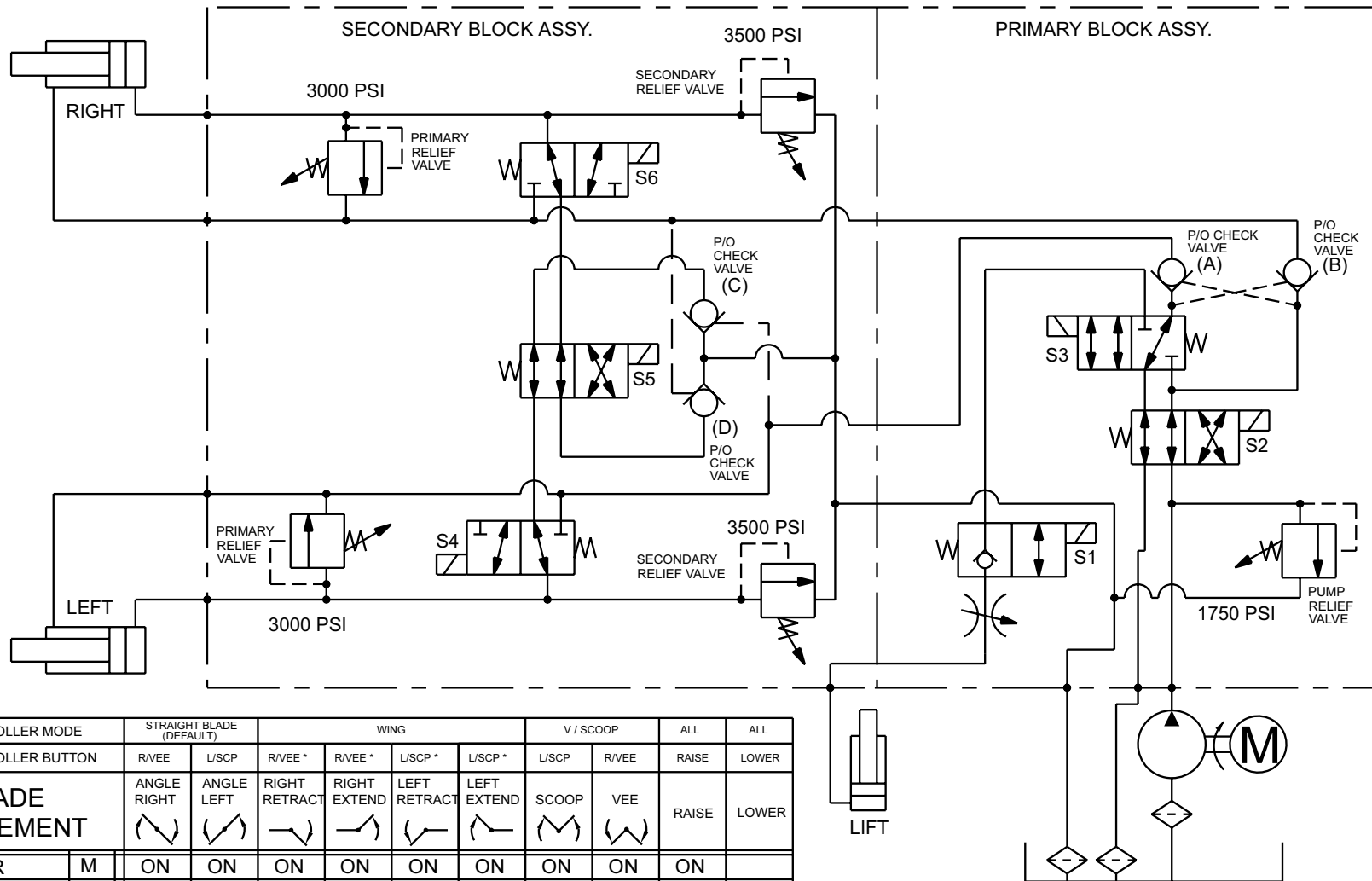

# ELECTRICAL SCHEMATIC



# HYDRAULIC SCHEMATIC



19

CONTROLLER MODE		STRAIGHT BLADE (DEFAULT)		WING				V / SCOOP		ALL	ALL
CONTROLLER BUTTON		R/VEE	L/SCP	R/VEE *	R/VEE *	L/SCP *	L/SCP *	L/SCP	R/VEE	RAISE	LOWER
<b>BLADE MOVEMENT</b>		ANGLE RIGHT 	ANGLE LEFT 	RIGHT RETRACT 	RIGHT EXTEND 	LEFT RETRACT 	LEFT EXTEND 	SCOOP 	VEE 	RAISE	LOWER
MOTOR	M	ON	ON	ON	ON	ON	ON	ON	ON	ON	
SV08-2004	S1										ON
SV08-40	S2		ON				ON	ON		ON	
SV08-43	S3							ON	ON	ON	ON
SV08-30	S4						ON	ON			
SV08-40	S5	ON	ON								
SV08-30	S6				ON			ON			

\* NOTE - SEE BLADE MOVEMENT TEXT FOR BUTTON OPERATION

# ANGLE RIGHT – ELECTRICAL

Blade Movement: Angle Right  
 Controller Mode: Straight Blade  
 Mode (Default)  
 Controller Button: R/VEE  
 System Response:

1) By pressing the controller button, the circuit board within the cab control completes the ground path for the electrical circuit.

2) Electrical current flows through the motor relay, activating the pump motor, and solenoid cartridge valve S5, shifting its spool.  
 3) Hydraulic oil from the pump flows through solenoid cartridge valve S2, P/O check valve (B) and into

the rod end of the right cylinder causing it to retract.  
 4) Pressure within the hydraulic circuit causes P/O check valves (A) & (D) to open.  
 5) The retracting right cylinder pushes the hydraulic oil out of its base end, through solenoid

cartridge valves S6 & S5 & S4 and into the base end of the left cylinder causing it to extend.  
 6) The extending left cylinder pushes the hydraulic oil out of its rod end, through P/O check valve (A), solenoid cartridge valves S3 & S2 and back to the reservoir.

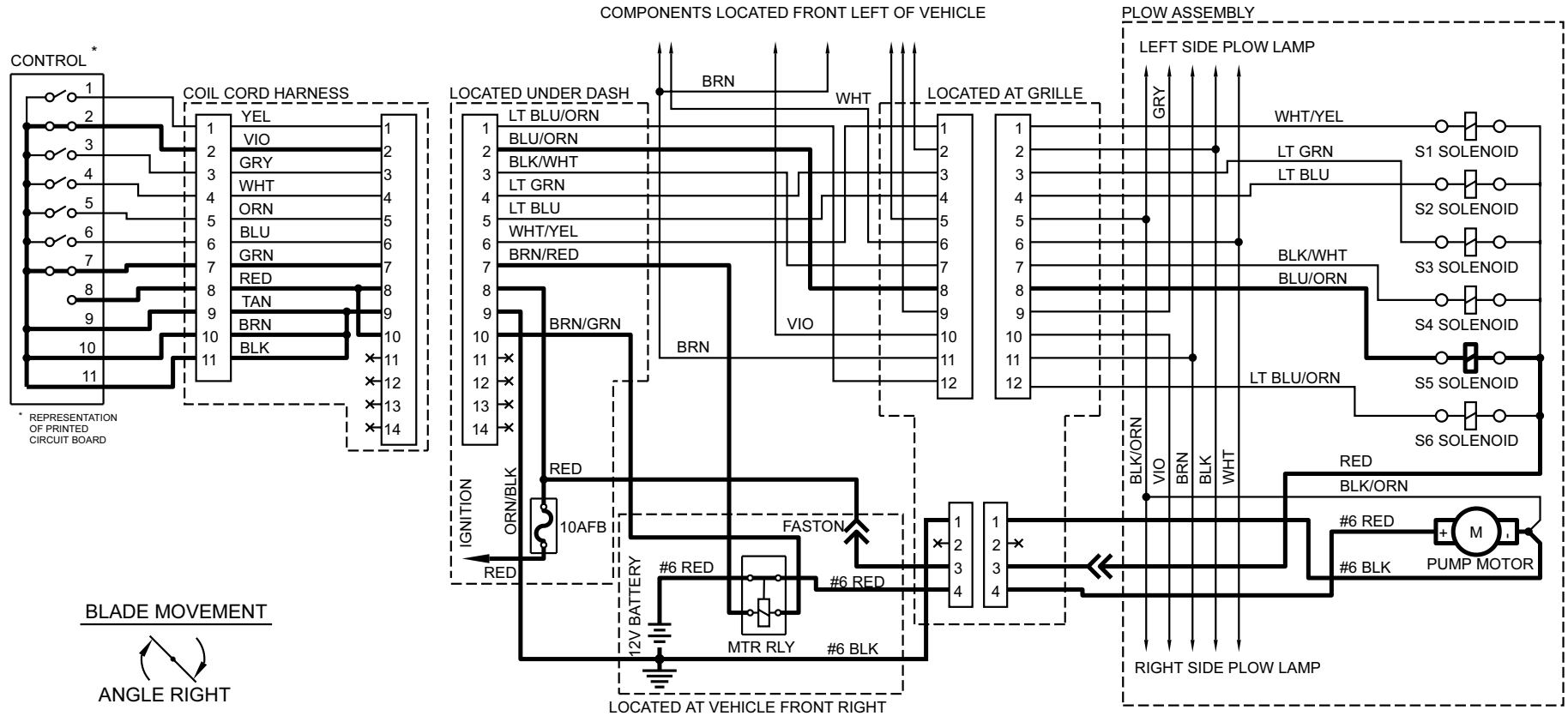

# ANGLE RIGHT – HYDRAULIC

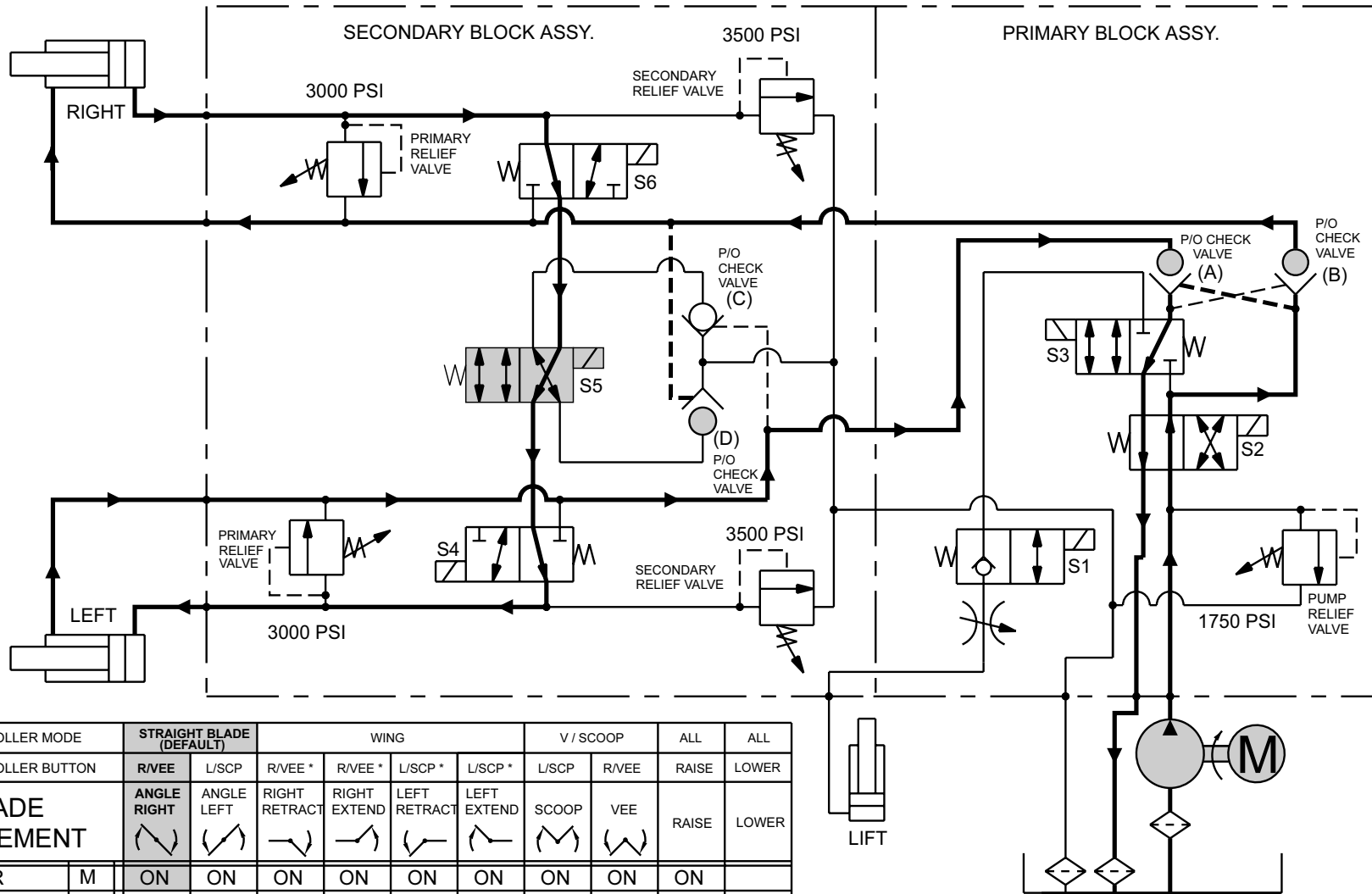

21

CONTROLLER MODE		STRAIGHT BLADE (DEFAULT)		WING				V / SCOOP		ALL	ALL
CONTROLLER BUTTON		R/VEE	L/SCP	R/VEE *	R/VEE *	L/SCP *	L/SCP *	L/SCP	R/VEE	RAISE	LOWER
<b>BLADE MOVEMENT</b>										RAISE	LOWER
MOTOR	M	ON	ON	ON	ON	ON	ON	ON	ON	ON	
SV08-2004	S1										ON
SV08-40	S2		ON			ON	ON			ON	
SV08-43	S3							ON	ON	ON	ON
SV08-30	S4						ON	ON			
SV08-40	S5	ON	ON								
SV08-30	S6				ON			ON			

\* NOTE - SEE BLADE MOVEMENT TEXT FOR BUTTON OPERATION

# ANGLE LEFT – ELECTRICAL

Blade Movement: Angle Left  
 Controller Mode: Straight Blade  
 Mode (Default)  
 Controller Button: L/SCP  
 System Response:

1) By pressing the controller button, the circuit board within the cab control completes the ground path for the electrical circuit.

2) Electrical current flows through the motor relay, activating the pump motor, and solenoid cartridge valves S2 & S5, shifting both spools.  
 3) Hydraulic oil from the pump flows through solenoid cartridge valves S2 & S3, P/O check valve (A)

and into the rod end of the left cylinder causing it to retract.  
 4) Pressure within the hydraulic circuit causes P/O check valves (B) & (C) to open.  
 5) The retracting left cylinder pushes the hydraulic oil out of its base end, through solenoid

cartridge valves S4 & S5 & S6 and into the base end of the right cylinder causing it to extend.  
 6) The extending right cylinder pushes the hydraulic oil out of its rod end, through P/O check valve (B), solenoid cartridge valve S2 and back to the reservoir.

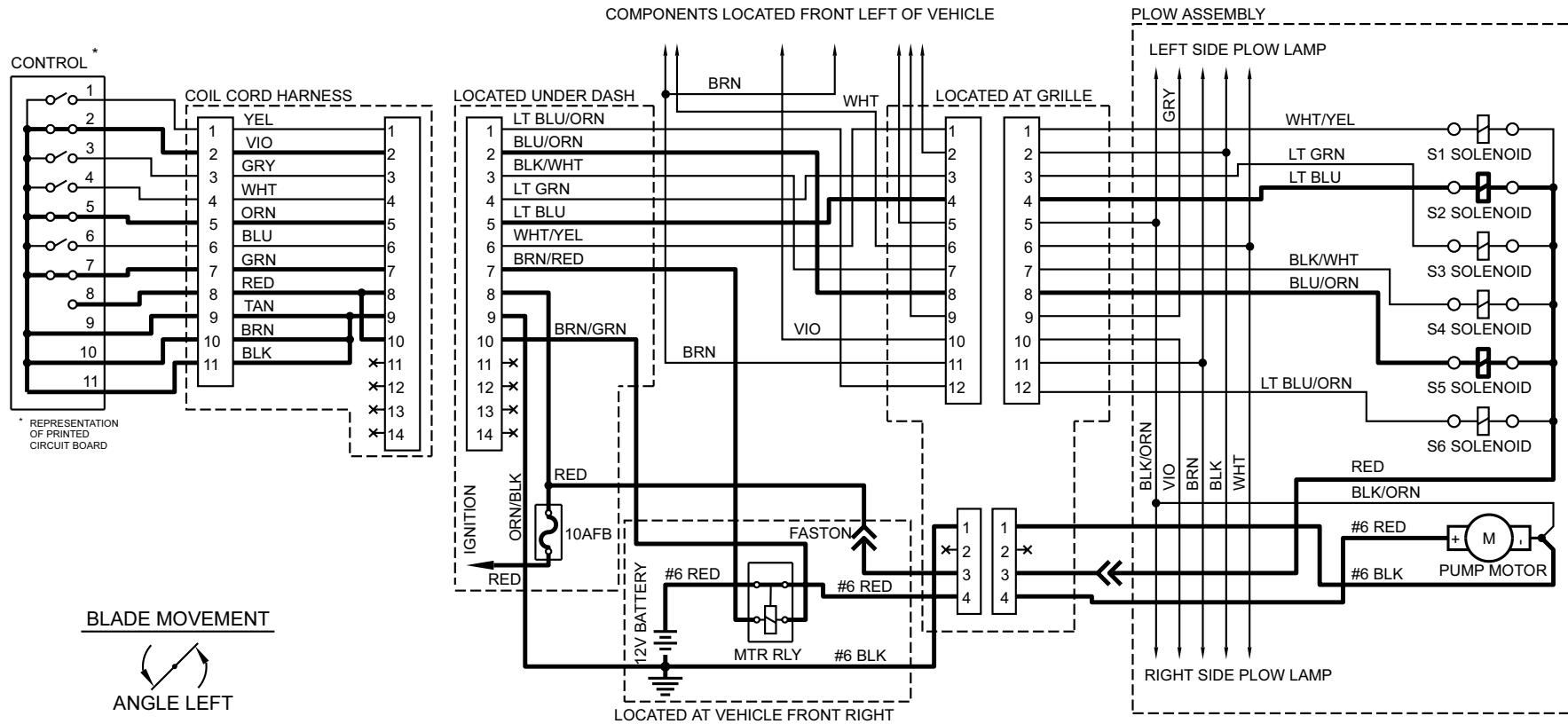

# ANGLE LEFT – HYDRAULIC

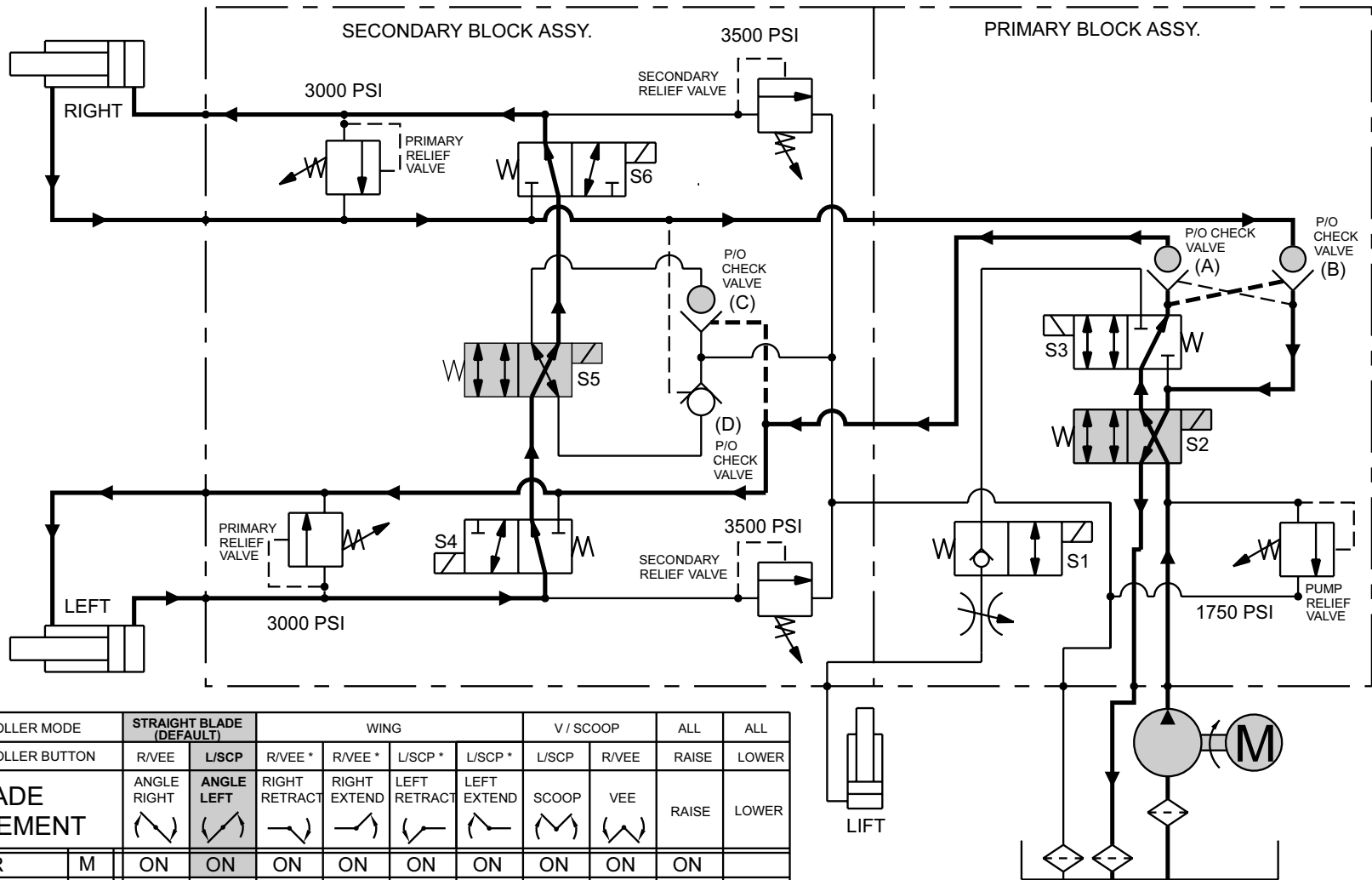

CONTROLLER MODE		STRAIGHT BLADE (DEFAULT)		WING				V / SCOOP		ALL	ALL
CONTROLLER BUTTON		R/VEE	L/SCP	R/VEE *	R/VEE *	L/SCP *	L/SCP *	L/SCP	R/VEE	RAISE	LOWER
<b>BLADE MOVEMENT</b>		ANGLE RIGHT	ANGLE LEFT	RIGHT RETRACT	RIGHT EXTEND	LEFT RETRACT	LEFT EXTEND	SCOOP	VEE	RAISE	LOWER
MOTOR	M	ON	ON	ON	ON	ON	ON	ON	ON	ON	ON
SV08-2004	S1										ON
SV08-40	S2		ON			ON	ON			ON	ON
SV08-43	S3							ON	ON	ON	ON
SV08-30	S4						ON	ON			
SV08-40	S5	ON	ON								
SV08-30	S6				ON			ON			

\* NOTE - SEE BLADE MOVEMENT TEXT FOR BUTTON OPERATION

# RIGHT RETRACT – ELECTRICAL

Blade Movement: Right Retract  
 Controller Mode: Wing Mode  
 Controller Button: R/VEE

*This button toggles between retract and extend in wing mode. Upon entering wing mode, the first activation of this button and every other activation thereafter retracts the wing. The second activation of*

*this button and every other activation thereafter extends the wing.*

System Response:

- 1) By pressing the controller button, the circuit board within the cab control completes the ground

- 2) Electrical current flows through the motor relay activating the pump motor.
- 3) Hydraulic oil from the pump flows through solenoid cartridge valve S2, P/O check valve (B) and into the rod end of the right cylinder causing it to retract.

- 4) Pressure within the hydraulic circuit causes P/O check valves (A) & (D) to open.
- 5) The retracting right cylinder pushes the hydraulic oil out of its base end, through solenoid cartridge valves S6 & S5, P/O check valve (D) and back to the reservoir.

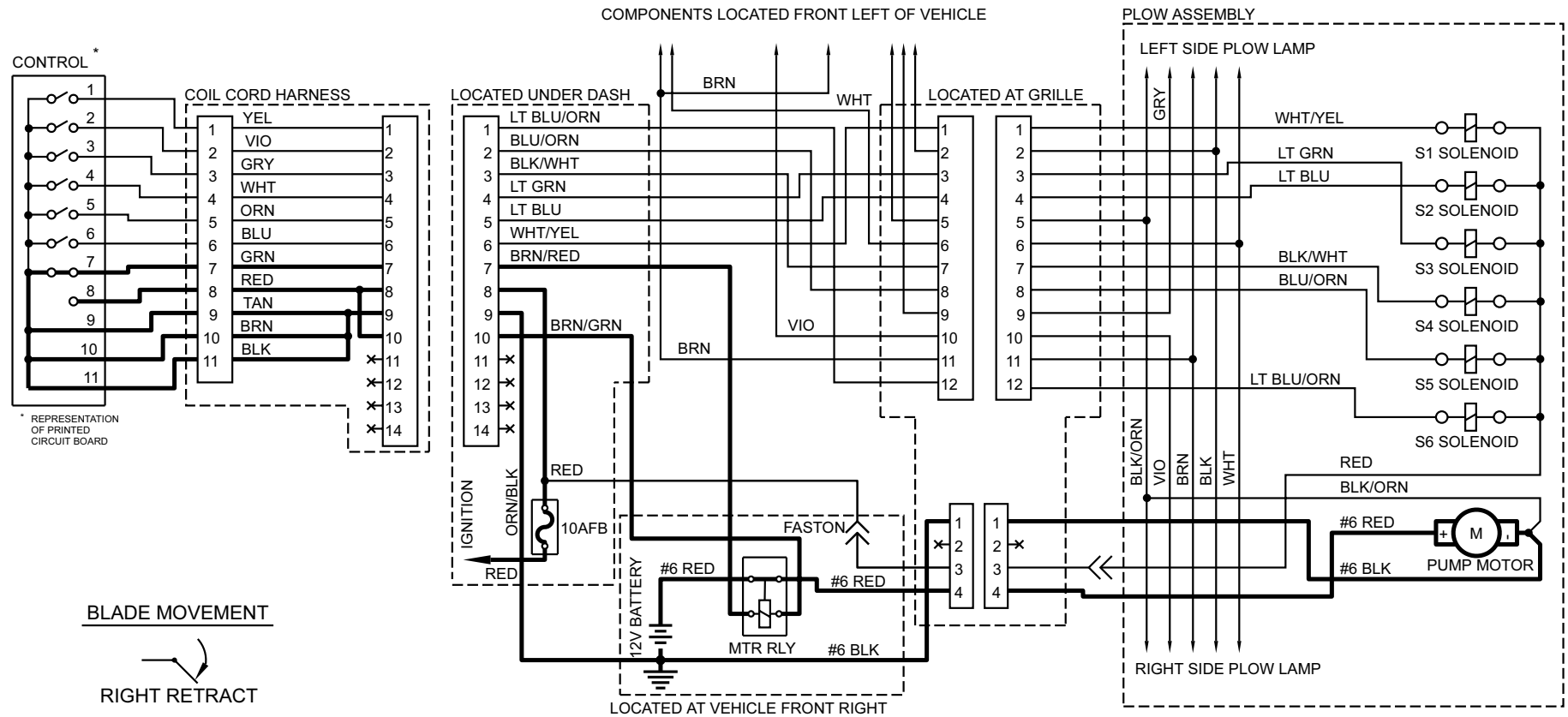



# RIGHT RETRACT – HYDRAULIC

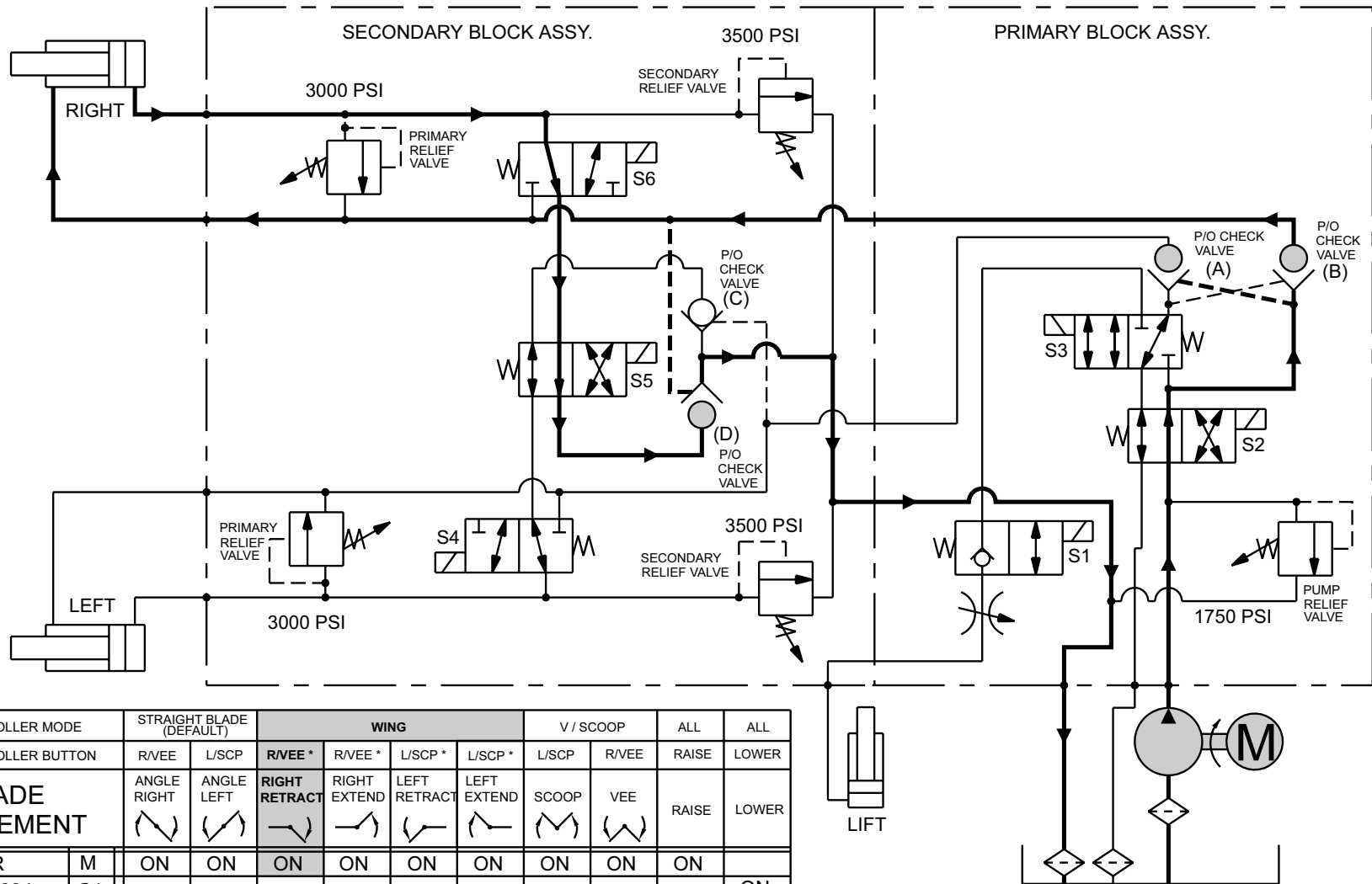

25

CONTROLLER MODE		STRAIGHT BLADE (DEFAULT)		WING				V / SCOOP		ALL	ALL
CONTROLLER BUTTON		R/VEE	L/SCP	R/VEE *	R/VEE *	L/SCP *	L/SCP *	L/SCP	R/VEE	RAISE	LOWER
<b>BLADE MOVEMENT</b>		ANGLE RIGHT 	ANGLE LEFT 	RIGHT RETRACT 	RIGHT EXTEND 	LEFT RETRACT 	LEFT EXTEND 	SCOOP 	VEE 	RAISE	LOWER
MOTOR	M	ON	ON	ON	ON	ON	ON	ON	ON	ON	
SV08-2004	S1										ON
SV08-40	S2		ON			ON	ON			ON	
SV08-43	S3							ON	ON	ON	ON
SV08-30	S4						ON	ON			
SV08-40	S5	ON	ON								
SV08-30	S6				ON			ON			

\* NOTE - SEE BLADE MOVEMENT TEXT FOR BUTTON OPERATION

# RIGHT EXTEND – ELECTRICAL

Blade Movement: Right Extend

Controller Mode: Wing Mode

Controller Button: R/VEE

*This button toggles between retract and extend in wing mode. Upon entering wing mode, the first activation of this button and every other activation thereafter retracts the wing. The second activation of this button and every other activation thereafter extends the wing.*

System Response:

- 1) By pressing the controller button, the circuit board within the cab control completes the ground path for the electrical circuit.
- 2) Electrical current flows through the motor relay, activating the pump motor, and solenoid cartridge valve S6, shifting its spool.
- 3) Hydraulic oil from the pump flows through solenoid cartridge valve
- 4) The extending right cylinder pushes the hydraulic oil out of its rod end. This oil mixes with the hydraulic oil from the pump, passes through solenoid cartridge valve S6 and into the base end of the extending right cylinder. This is called a *regenerative hydraulic circuit*.

*Even though both sides of the cylinder piston will experience the same hydraulic pressure, the cylinder will extend due to unequal force. The difference in area between the base end and rod end of the cylinder piston creates a greater force on the base end which extends the cylinder. Force = Pressure X Surface Area.*

- 5) Pressure within the hydraulic circuit causes P/O check valves (A) & (D) to open.

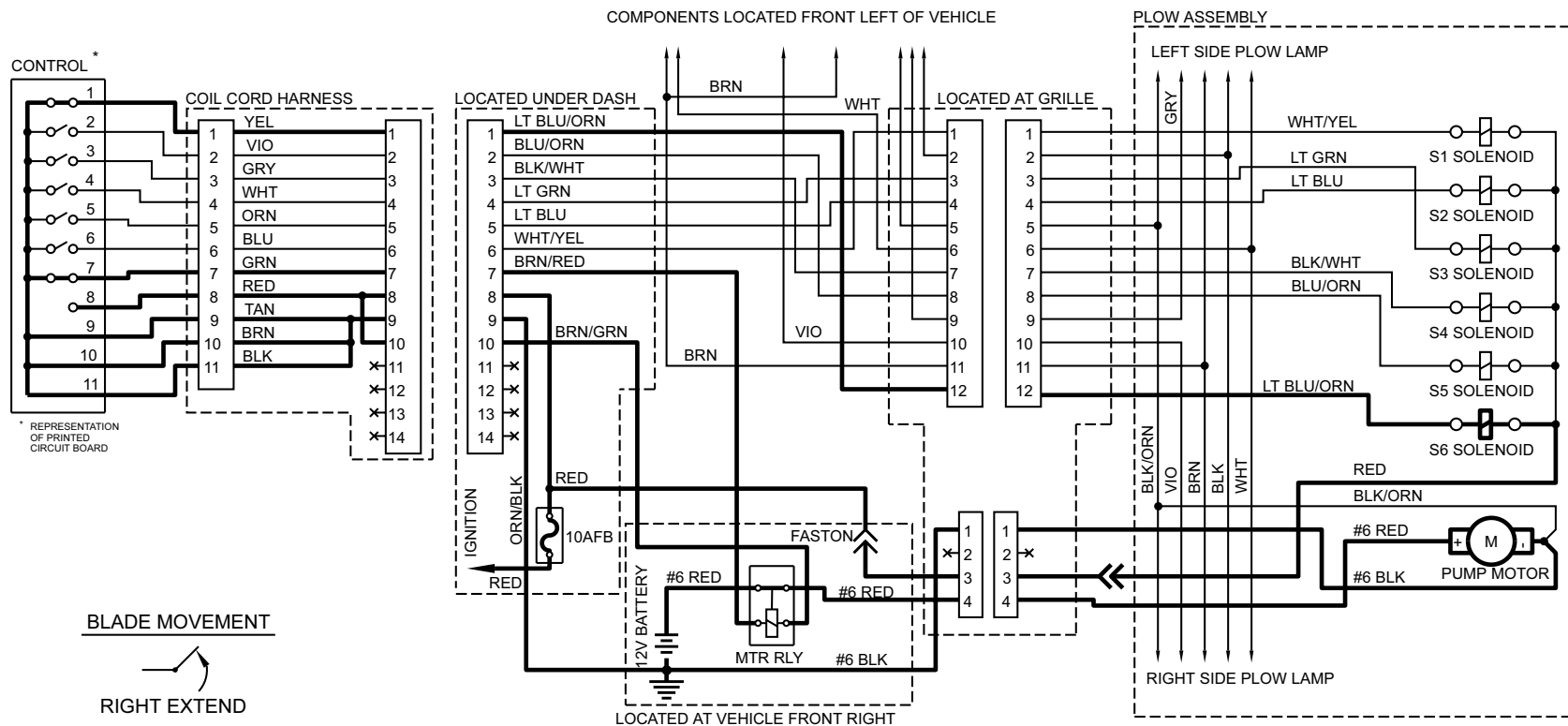

# RIGHT EXTEND – HYDRAULIC

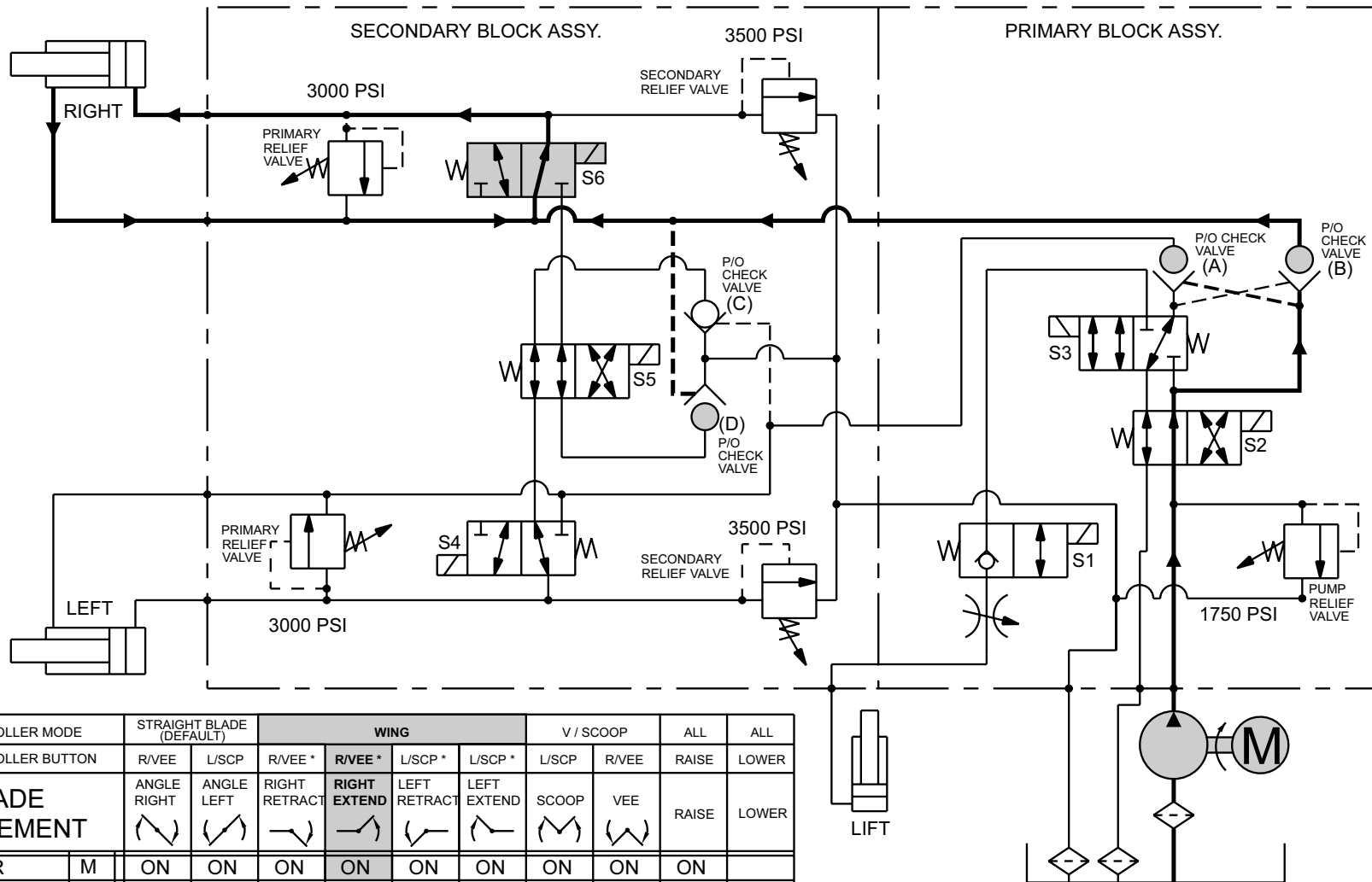

CONTROLLER MODE		STRAIGHT BLADE (DEFAULT)		WING			V / SCOOP		ALL	ALL	
CONTROLLER BUTTON		R/VEE	L/SCP	R/VEE *	R/VEE *	L/SCP *	L/SCP *	L/SCP	R/VEE	RAISE	LOWER
<b>BLADE MOVEMENT</b>		ANGLE RIGHT	ANGLE LEFT	RIGHT RETRACT	<b>RIGHT EXTEND</b>	LEFT RETRACT	LEFT EXTEND	SCOOP	VEE	RAISE	LOWER
MOTOR	M	ON	ON	ON	ON	ON	ON	ON	ON	ON	
SV08-2004	S1										ON
SV08-40	S2		ON			ON	ON			ON	ON
SV08-43	S3							ON	ON	ON	ON
SV08-30	S4						ON	ON			
SV08-40	S5	ON	ON								
SV08-30	S6				ON			ON			

\* NOTE - SEE BLADE MOVEMENT TEXT FOR BUTTON OPERATION

# LEFT RETRACT – ELECTRICAL

Blade Movement: Left Retract

Controller Mode: Wing Mode

Controller Button: L/SCP

*This button toggles between retract and extend in wing mode. Upon entering wing mode, the first activation of this button and every other activation thereafter retracts the wing. The second activation of this button and every other activation thereafter extends the wing.*

System Response:

- 1) By pressing the controller button, the circuit board within the cab control completes the ground path for the electrical circuit.
- 2) Electrical current flows through the motor relay, activating the pump motor, and solenoid cartridge valve S2, shifting its spool.
- 3) Hydraulic oil from the pump flows through solenoid cartridge valves S2 & S3, P/O check valve (A), and into the rod end of the left cylinder causing it to retract.
- 4) Pressure within the hydraulic circuit causes P/O check valves (B) & (C) to open.
- 5) The retracting left cylinder pushes the hydraulic oil out of its base end, through solenoid cartridge valves S4 & S5, through P/O check valve (C) and back to the reservoir.

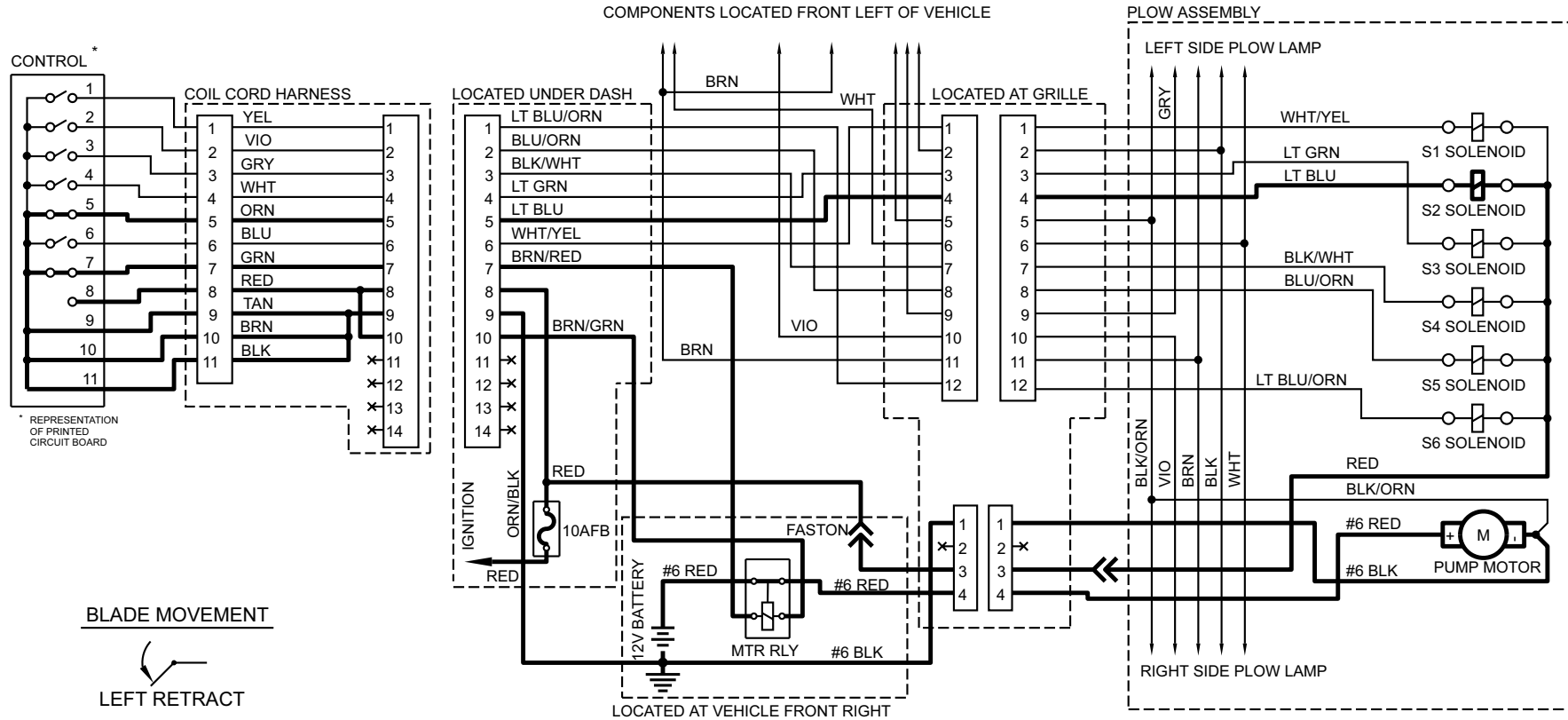

# LEFT RETRACT – HYDRAULIC

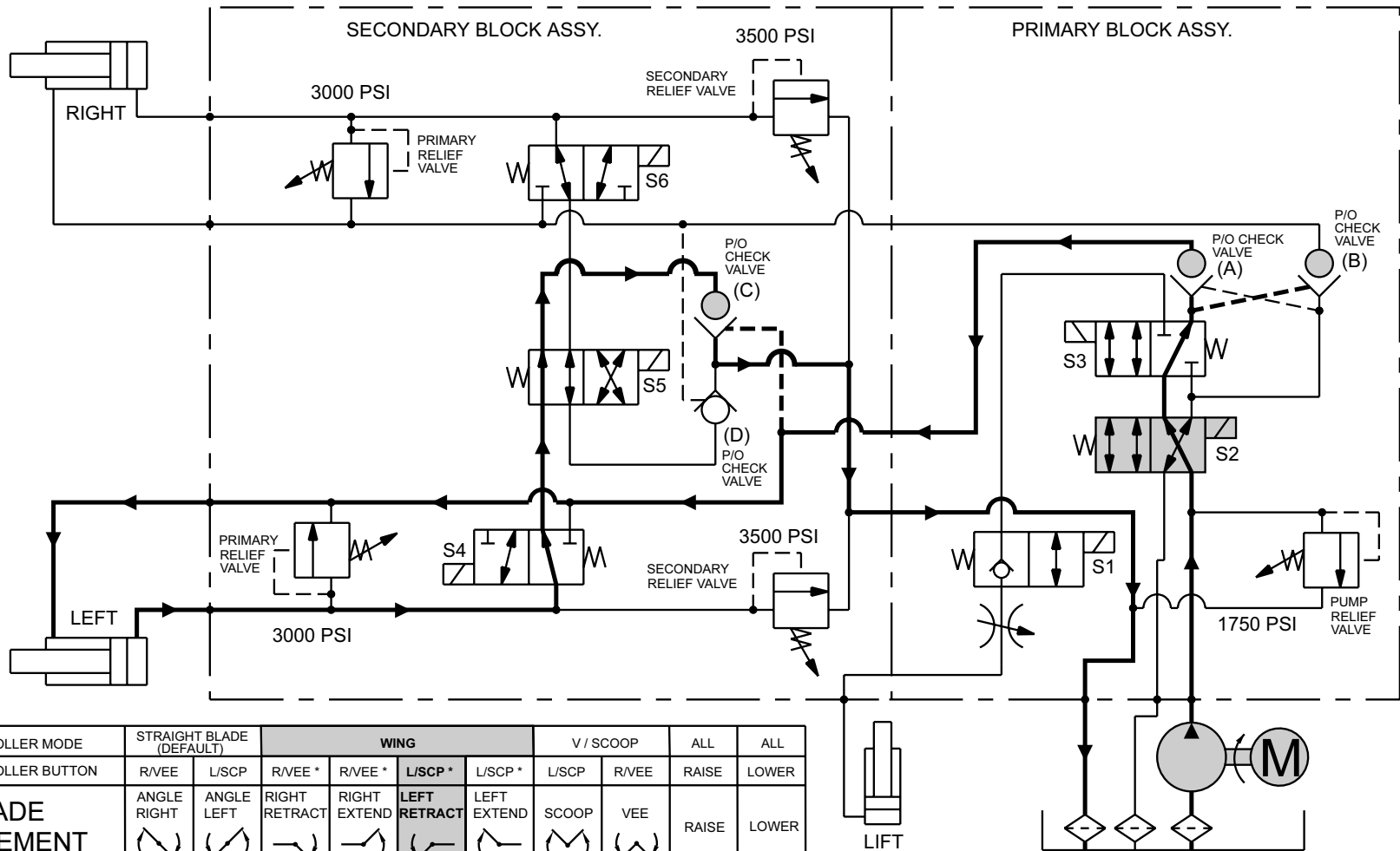

CONTROLLER MODE		STRAIGHT BLADE (DEFAULT)		WING				V / SCOOP		ALL	ALL
CONTROLLER BUTTON		R/VEE	L/SCP	R/VEE *	R/VEE *	L/SCP *	L/SCP *	L/SCP	R/VEE	RAISE	LOWER
<b>BLADE MOVEMENT</b>		ANGLE RIGHT 	ANGLE LEFT 	RIGHT RETRACT 	RIGHT EXTEND 	<b>LEFT RETRACT</b> 	LEFT EXTEND 	SCOOP 	VEE 	RAISE	LOWER
MOTOR	M	ON	ON	ON	ON	ON	ON	ON	ON	ON	ON
SV08-2004	S1										ON
SV08-40	S2		ON			ON	ON			ON	ON
SV08-43	S3							ON	ON	ON	ON
SV08-30	S4						ON	ON			
SV08-40	S5	ON	ON								
SV08-30	S6				ON			ON			

\* NOTE - SEE BLADE MOVEMENT TEXT FOR BUTTON OPERATION

# LEFT EXTEND – ELECTRICAL

Blade Movement: Left Extend  
 Controller Mode: Wing Mode  
 Controller Button: L/SCP

*This button toggles between retract and extend in wing mode. Upon entering wing mode, the first activation of this button and every other activation thereafter retracts the wing. The second activation of this button and every other activation thereafter extends the wing.*

System Response:

- 1) By pressing the controller button, the circuit board within the cab control completes the ground path for the electrical circuit.
- 2) Electrical current flows through the motor relay, activating the pump motor, and solenoid cartridge valves S2 & S4, shifting both spools.
- 3) Hydraulic oil from the pump flows through solenoid cartridge valves
- 4) The extending left cylinder pushes the hydraulic oil out of its rod end. This oil mixes with the hydraulic oil from the pump, passes through solenoid cartridge valve S4 and into the base end of the extending left cylinder. This is called a *regenerative hydraulic circuit*.

*Even though both sides of the cylinder piston will experience the same hydraulic pressure, the cylinder will extend due to unequal force. The difference in area between the base end and rod end of the cylinder piston creates a greater force on the base end which extends the cylinder. Force = Pressure X Surface Area.*

- 5) Pressure within the hydraulic circuit causes P/O check valves (B) & (C) to open.

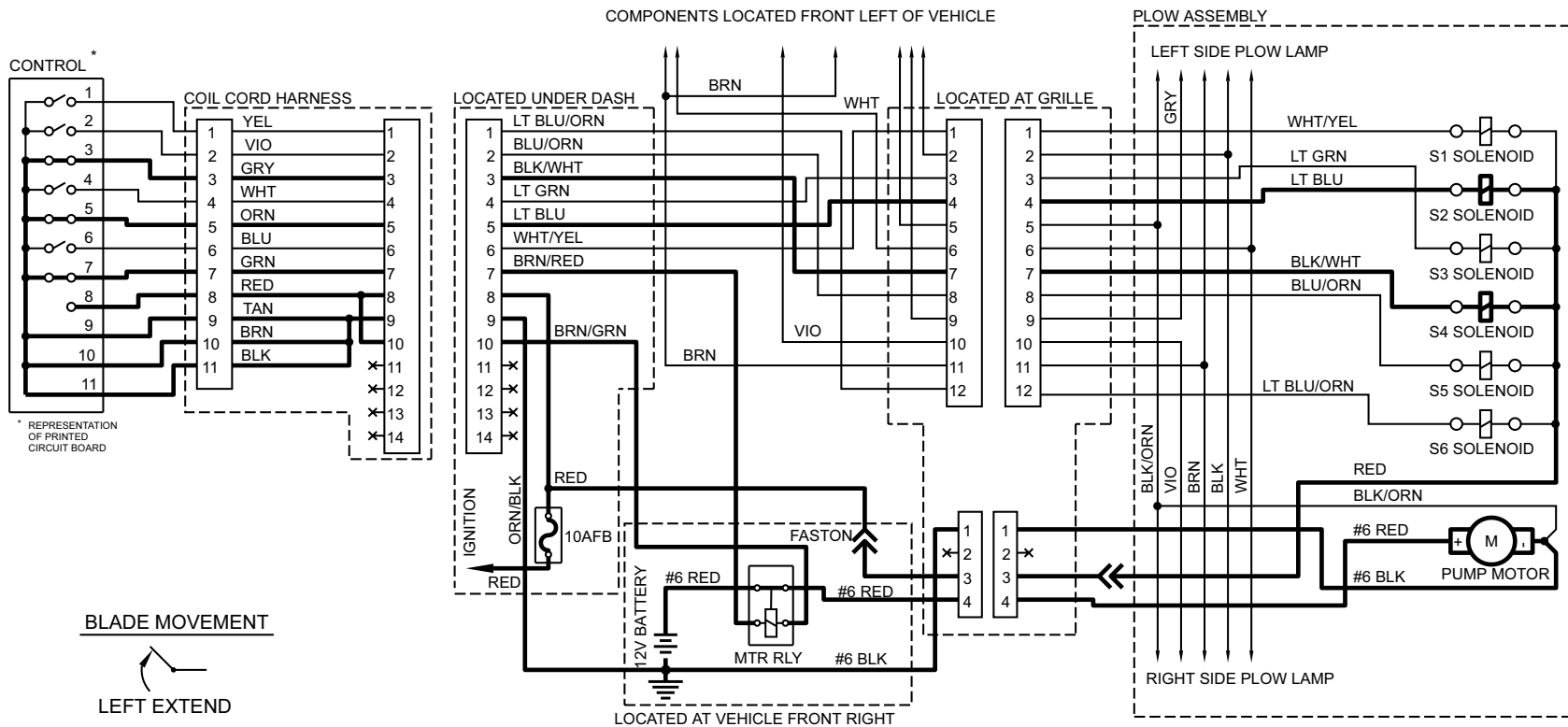

# LEFT EXTEND – HYDRAULIC

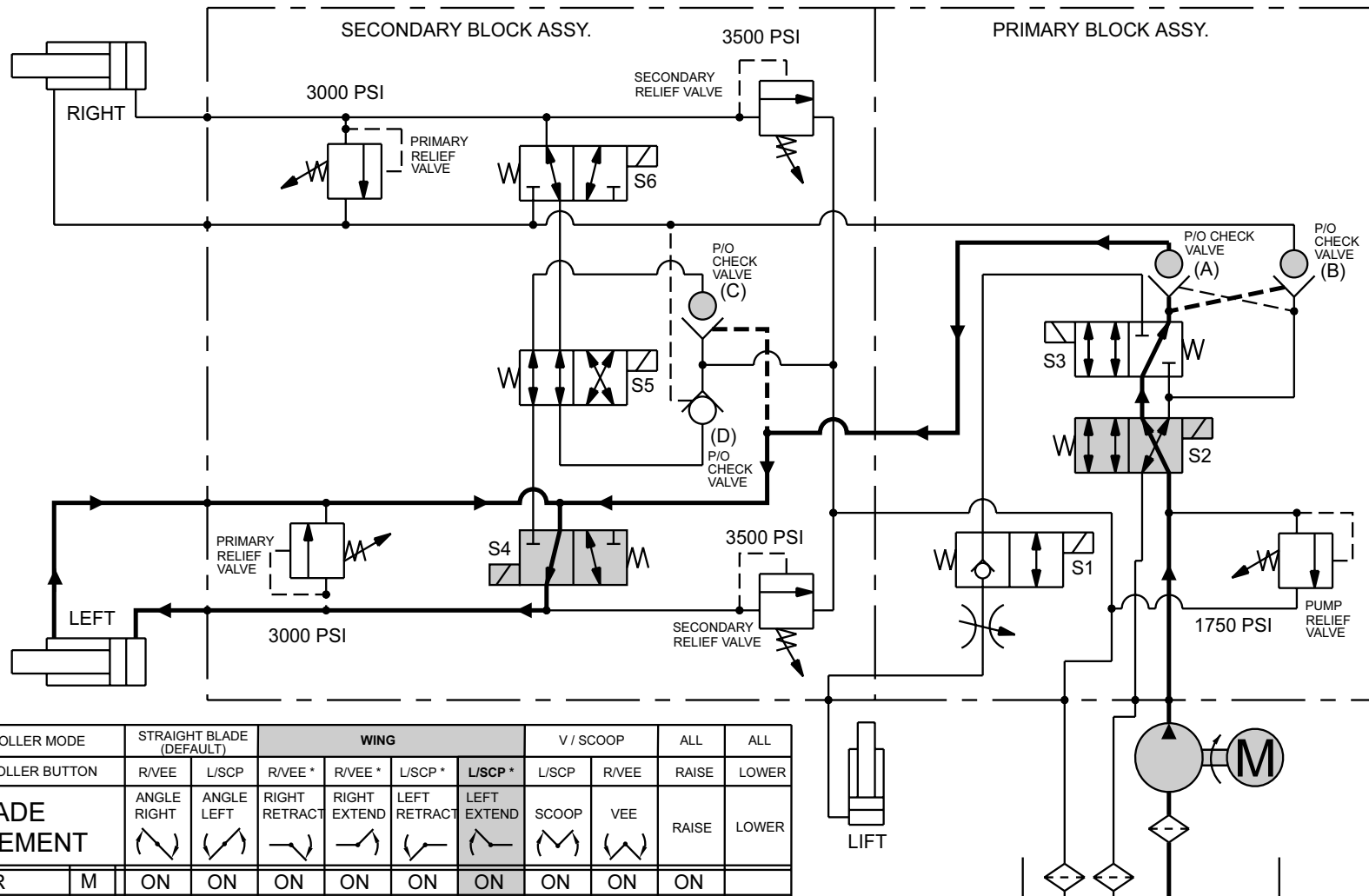

CONTROLLER MODE		STRAIGHT BLADE (DEFAULT)		WING				V / SCOOP		ALL	ALL
CONTROLLER BUTTON		R/VEE	L/SCP	R/VEE *	R/VEE *	L/SCP *	L/SCP *	L/SCP	R/VEE	RAISE	LOWER
<b>BLADE MOVEMENT</b>		ANGLE RIGHT	ANGLE LEFT	RIGHT RETRACT	RIGHT EXTEND	LEFT RETRACT	LEFT EXTEND	SCOOP	VEE	RAISE	LOWER
MOTOR	M	ON	ON	ON	ON	ON	ON	ON	ON	ON	
SV08-2004	S1										ON
SV08-40	S2		ON			ON	ON			ON	
SV08-43	S3							ON	ON	ON	ON
SV08-30	S4						ON	ON			
SV08-40	S5	ON	ON								
SV08-30	S6				ON			ON			

\* NOTE - SEE BLADE MOVEMENT TEXT FOR BUTTON OPERATION

# SCOOP – ELECTRICAL

Blade Movement: Scoop  
 Controller Mode: V / Scoop Mode  
 Controller Button: L/SCP  
 System Response:

- 1) By pressing the controller button, the circuit board within the cab control completes the ground path for the electrical circuit.
- 2) Electrical current flows through the motor relay, activating the pump motor, and solenoid cartridge valves S3 & S4 & S6,

- 3) Hydraulic oil from the pump flows through solenoid cartridge valve S2 and into two separate hydraulic circuits.
- 4) Half of the oil flows through P/O check valve (B), solenoid cartridge valve S6 and into the base end of the right cylinder causing it to extend. The extending right cylinder pushes the hydraulic oil out of its rod end. This oil mixes with the hydraulic

oil from the pump, passes through solenoid cartridge valve S6 and into the base end of the extending right cylinder. This is called a *regenerative hydraulic circuit*. Even though both sides of the cylinder piston will experience the same hydraulic pressure, the cylinder will extend due to unequal force. The difference in area between the base end and rod end of the cylinder piston creates a greater

- 5) The other half of the oil flows through solenoid cartridge valve S3, P/O check valve (A), solenoid cartridge valve S4 and into the base end of the left cylinder causing it to extend. The extending left cylinder pushes the hydraulic oil out of its rod end. This oil mixes with the hydraulic oil from the pump, passes

through solenoid cartridge valve S4 and into the base end of the extending left cylinder. This is also a *regenerative hydraulic circuit*.  
 6) Pressure within the hydraulic circuit causes P/O check valves (C) & (D) to open.

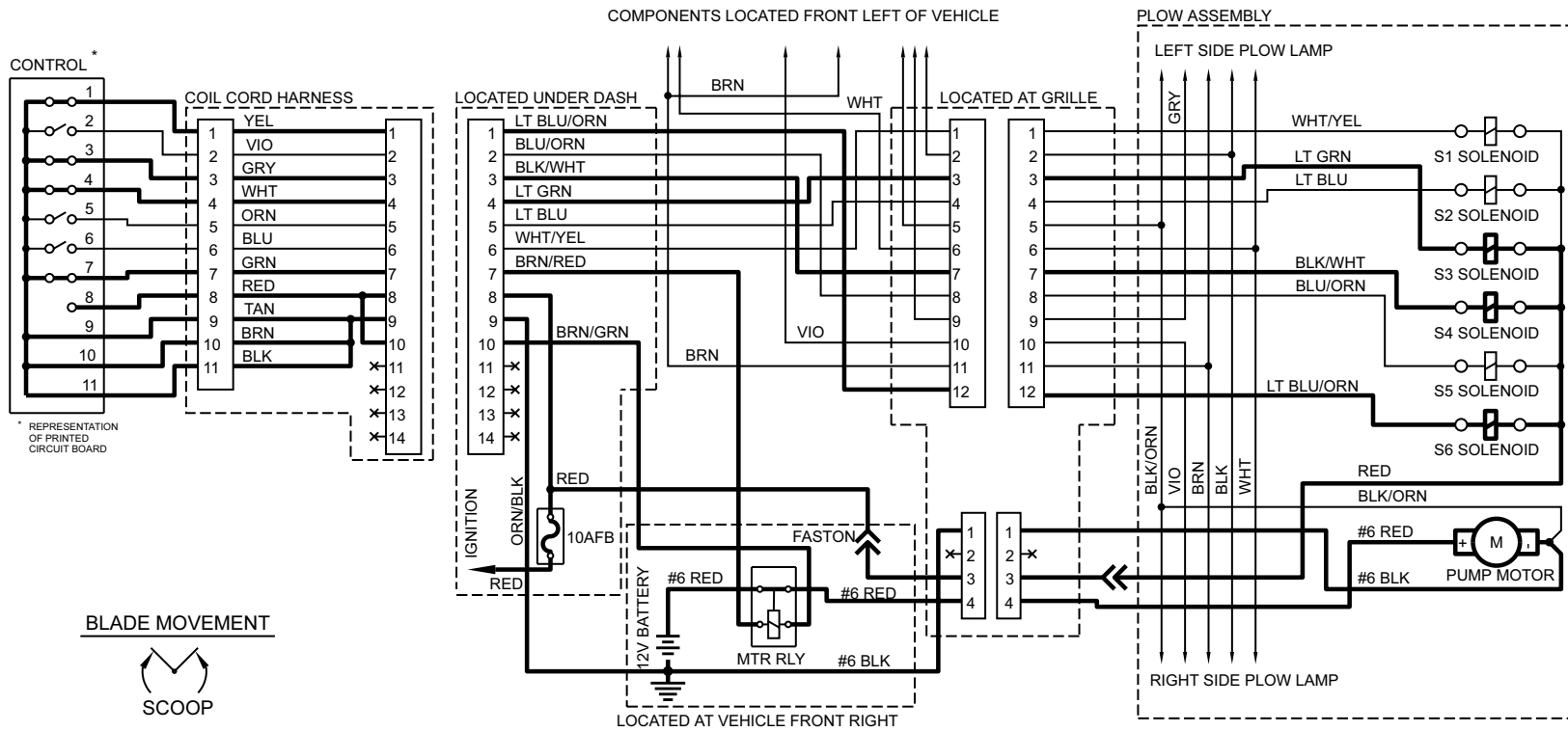



# SCOOP – HYDRAULIC

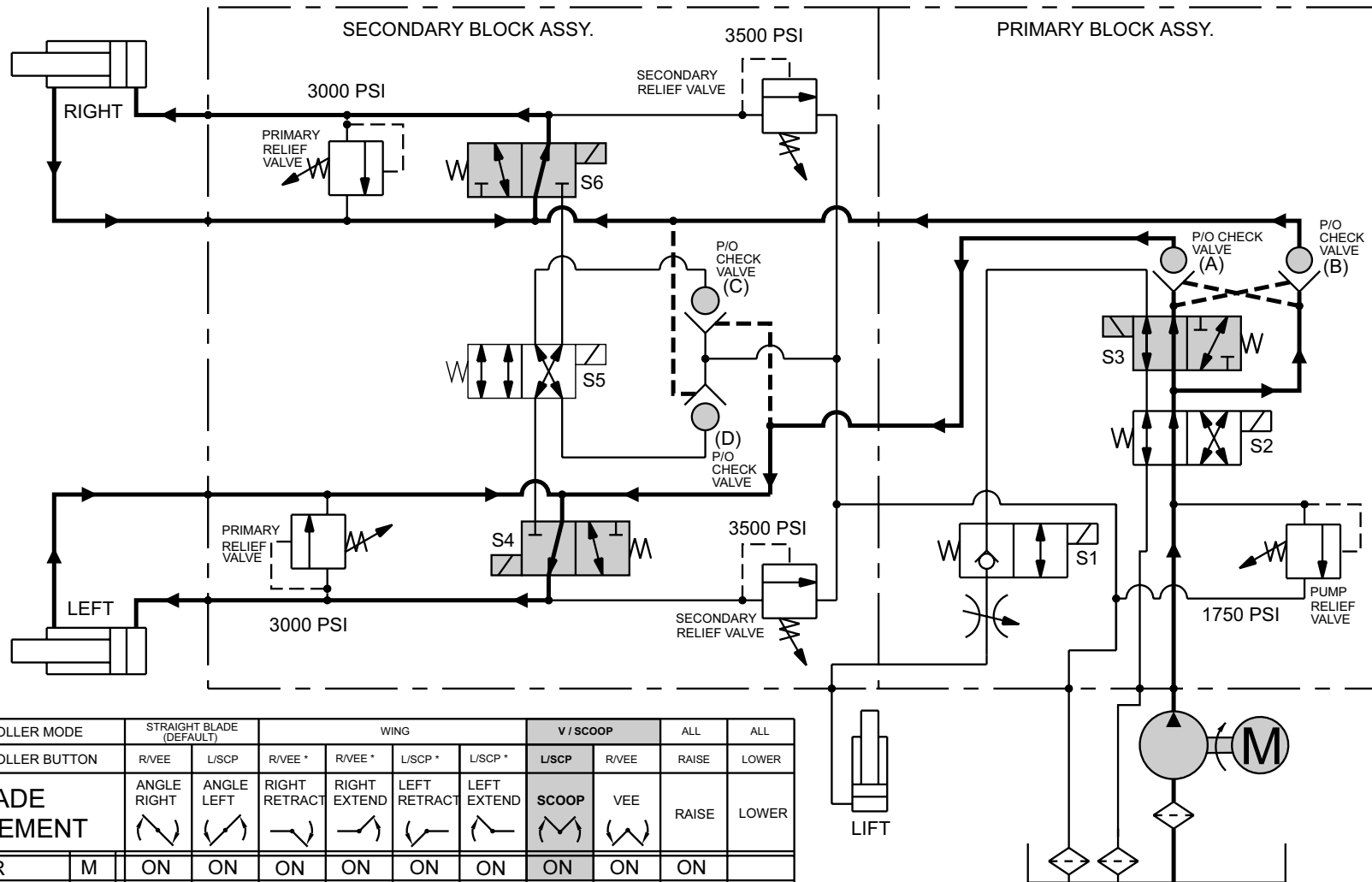

CONTROLLER MODE	STRAIGHT BLADE (DEFAULT)		WING				V / SCOOP		ALL	ALL
	R/VEE	L/SCP	R/VEE *	R/VEE *	L/SCP *	L/SCP *	L/SCP	R/VEE	RAISE	LOWER
<b>BLADE MOVEMENT</b>	ANGLE RIGHT 	ANGLE LEFT 	RIGHT RETRACT 	RIGHT EXTEND 	LEFT RETRACT 	LEFT EXTEND 	SCOOP 	VEE 	RAISE	LOWER
MOTOR	M	ON	ON	ON	ON	ON	ON	ON	ON	
SV08-2004	S1									ON
SV08-40	S2		ON			ON	ON		ON	
SV08-43	S3						ON	ON	ON	ON
SV08-30	S4						ON			
SV08-40	S5	ON	ON							
SV08-30	S6				ON		ON			

\* NOTE - SEE BLADE MOVEMENT TEXT FOR BUTTON OPERATION

# VEE – ELECTRICAL

Blade Movement: Vee  
 Controller Mode: V / Scoop Mode  
 Controller Button: R/VEE  
 System Response:

- 1) By pressing the controller button, the circuit board within the cab control completes the ground path for the electrical circuit.
- 2) Electrical current flows through the motor relay, activating the pump motor, and solenoid

- 3) Hydraulic oil from the pump flows through solenoid cartridge valve S2 and into two separate hydraulic circuits.
- 4) Half of the oil flows through P/O check valve (B) and into the rod end of the right cylinder causing it to retract.

- 5) The other half of the oil flows through solenoid cartridge valve S3, shifting its spool.
- 6) Pressure within the hydraulic circuit causes P/O check valves (C) & (D) to open.
- 7) The retracting right cylinder pushes the hydraulic oil out of its

- base end, through solenoid cartridge valves S6 & S5, P/O check valve (D) and back to the reservoir.
- 8) The retracting left cylinder pushes the hydraulic oil out of its base end, through solenoid cartridge valves S4 & S5, through P/O check valve (C) and back to the reservoir.

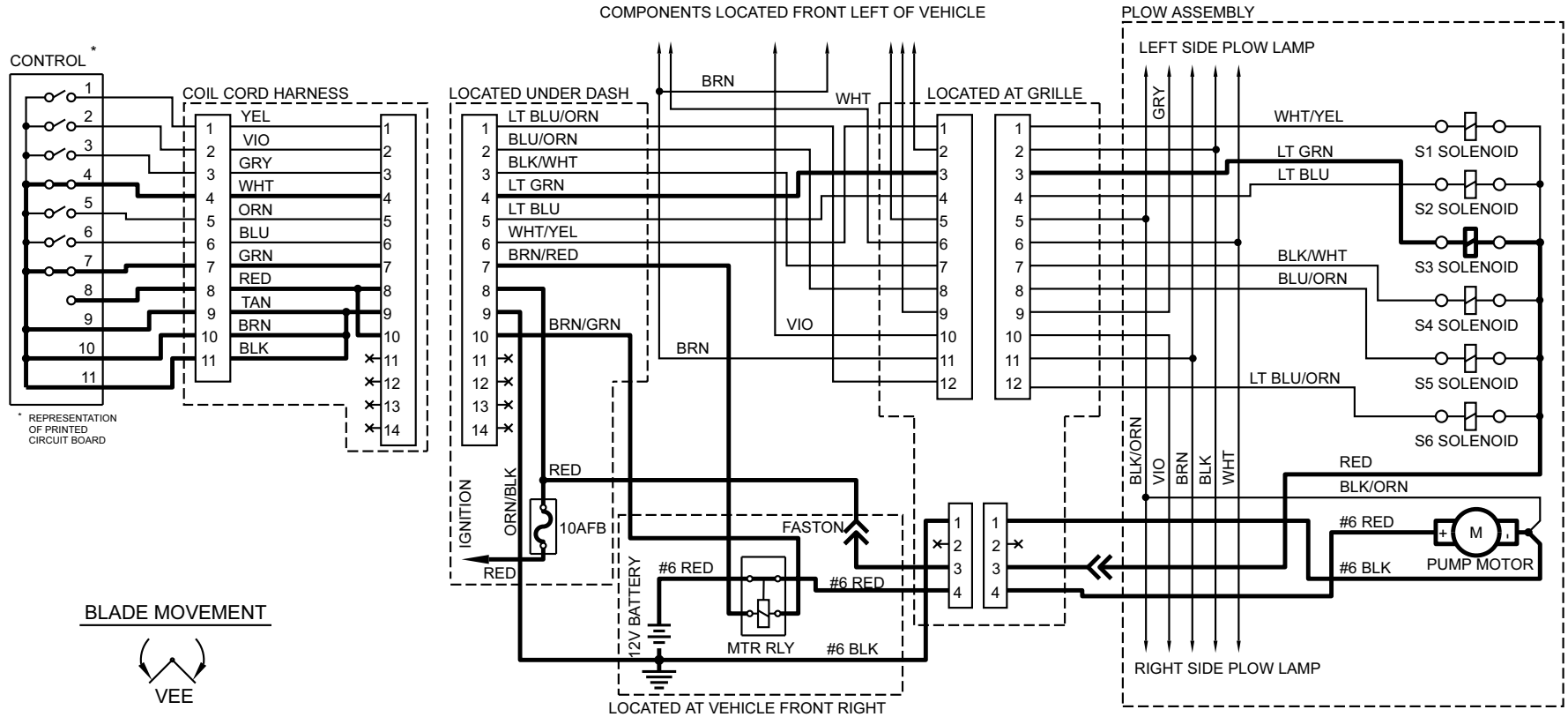

# VEE – HYDRAULIC

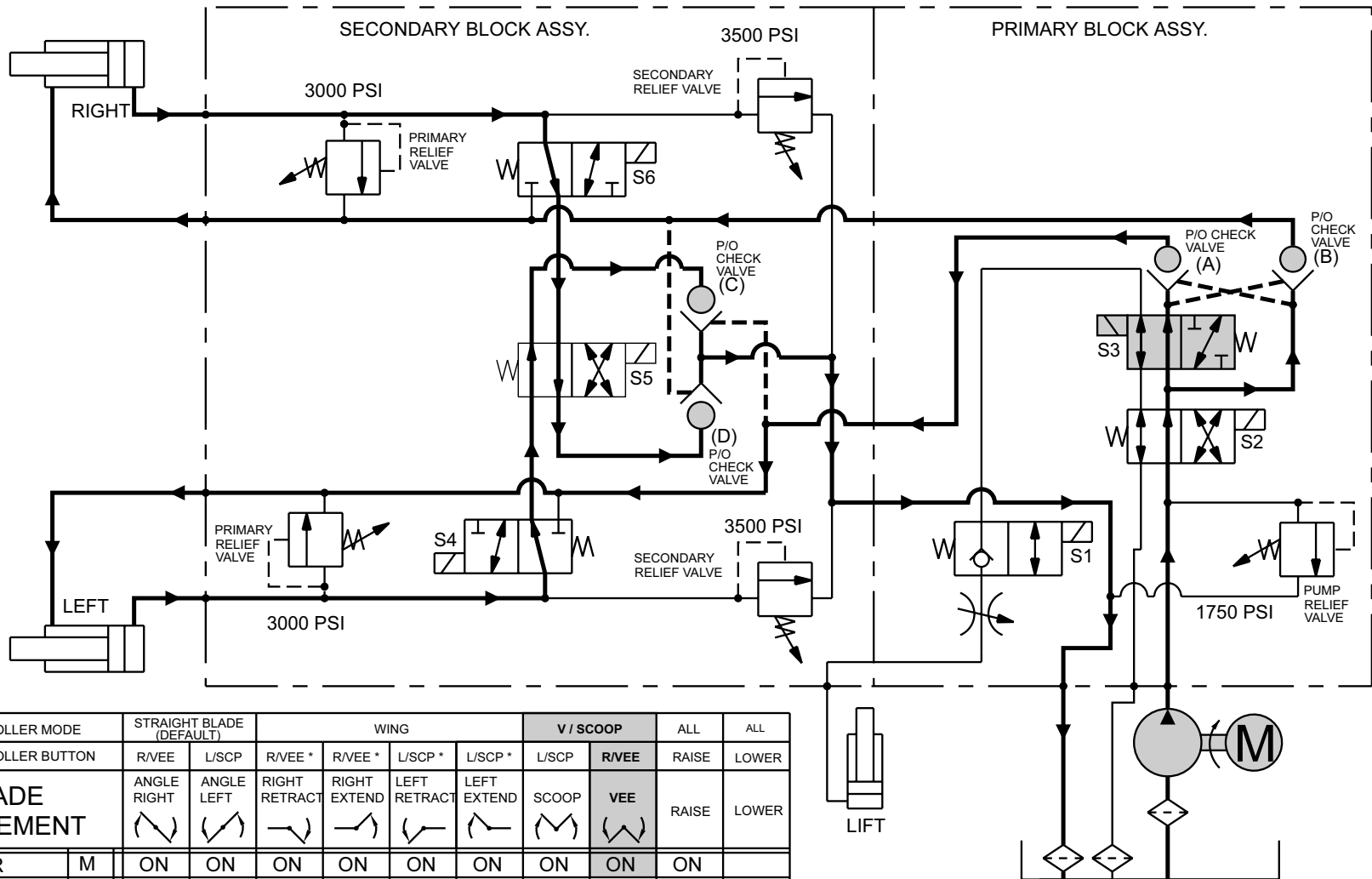

35

CONTROLLER MODE		STRAIGHT BLADE (DEFAULT)		WING				V / SCOOP		ALL	ALL
CONTROLLER BUTTON		R/VEE	L/SCP	R/VEE *	R/VEE *	L/SCP *	L/SCP *	L/SCP	R/VEE	RAISE	LOWER
<b>BLADE MOVEMENT</b>		ANGLE RIGHT	ANGLE LEFT	RIGHT RETRACT	RIGHT EXTEND	LEFT RETRACT	LEFT EXTEND	SCOOP	VEE	RAISE	LOWER
MOTOR	M	ON	ON	ON	ON	ON	ON	ON	ON	ON	
SV08-2004	S1										ON
SV08-40	S2		ON			ON	ON			ON	
SV08-43	S3							ON	ON	ON	ON
SV08-30	S4						ON	ON			
SV08-40	S5	ON	ON								
SV08-30	S6				ON			ON			

\* NOTE - SEE BLADE MOVEMENT TEXT FOR BUTTON OPERATION

# RAISE – ELECTRICAL

Blade Movement: Raise  
 Controller Mode: All Modes  
 Controller Button: Raise  
 System Response:

1) By pressing the controller button, the circuit board within the cab

control completes the ground path for the electrical circuit.  
 2) Electrical current flows through the motor relay, activating the pump motor, and solenoid cartridge valves S2 & S3, shifting both spools.

3) Hydraulic oil from the pump flows through solenoid cartridge valves S2 & S3, through the internal check valve in solenoid cartridge valve S1 into the base end of the lift cylinder causing it to extend.

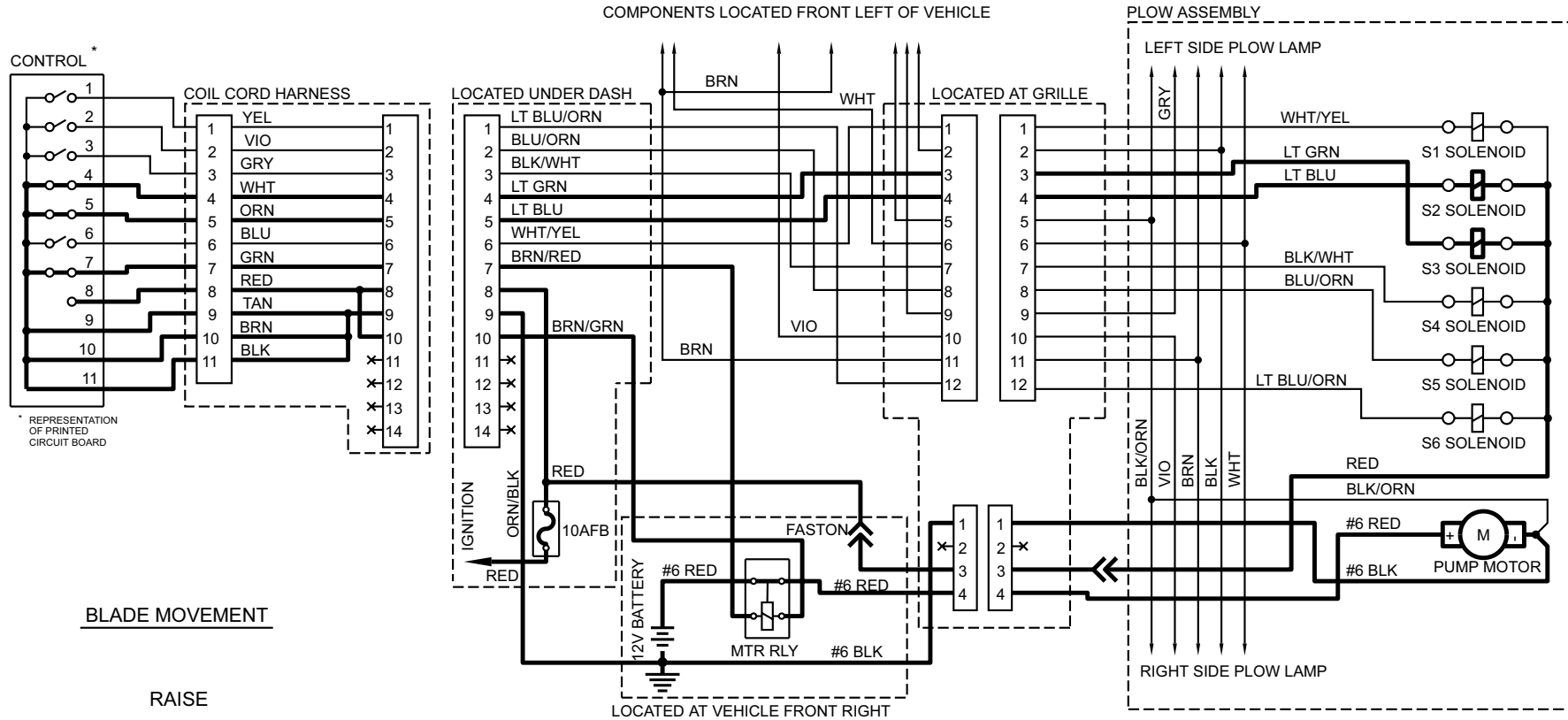

BLADE MOVEMENT

RAISE

# RAISE – HYDRAULIC

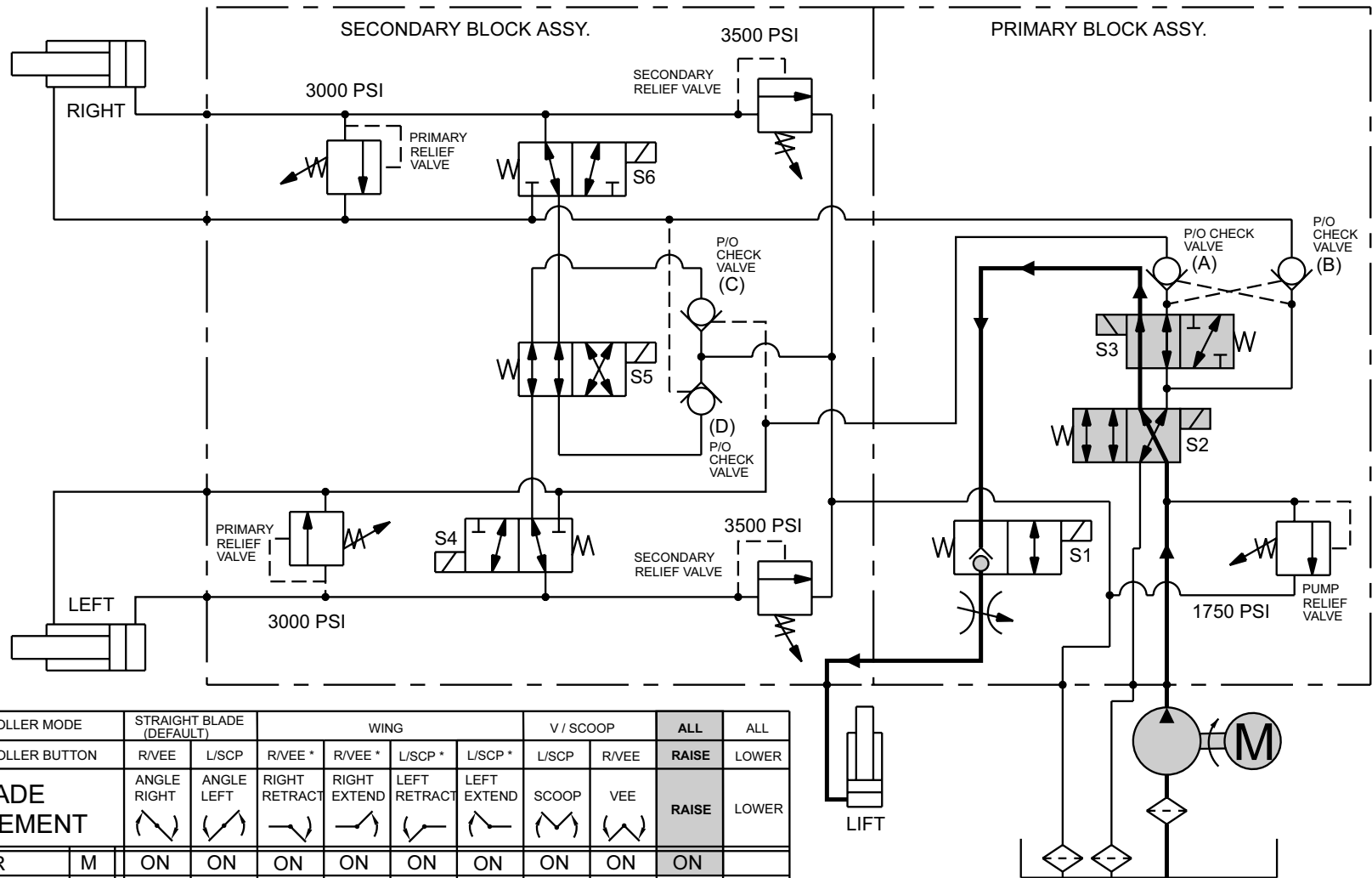

37

CONTROLLER MODE		STRAIGHT BLADE (DEFAULT)		WING				V / SCOOP		ALL	ALL
CONTROLLER BUTTON		R/VEE	L/SCP	R/VEE *	R/VEE *	L/SCP *	L/SCP *	L/SCP	R/VEE	RAISE	LOWER
<b>BLADE MOVEMENT</b>		ANGLE RIGHT	ANGLE LEFT	RIGHT RETRACT	RIGHT EXTEND	LEFT RETRACT	LEFT EXTEND	SCOOP	VEE	RAISE	LOWER
MOTOR	M	ON	ON	ON	ON	ON	ON	ON	ON	ON	
SV08-2004	S1										ON
SV08-40	S2		ON			ON	ON			ON	
SV08-43	S3							ON	ON	ON	ON
SV08-30	S4						ON	ON			
SV08-40	S5	ON	ON								
SV08-30	S6				ON			ON			

\* NOTE - SEE BLADE MOVEMENT TEXT FOR BUTTON OPERATION

# LOWER – ELECTRICAL

Blade Movement: Lower / Float  
 Controller Mode: All Modes  
 Controller Button: Lower  
 System Response:

1) By pressing the controller button, the circuit board within the cab

control completes the ground path for the electrical circuit.

- 2) Electrical current flows through solenoid cartridge valves S1 & S3 shifting both spools.
- 3) The weight of the plow forces the lift cylinder to retract. The

retracting lift cylinder pushes the hydraulic oil out of its base end, through solenoid cartridge valves S1 & S3 & S2, and back to the reservoir.

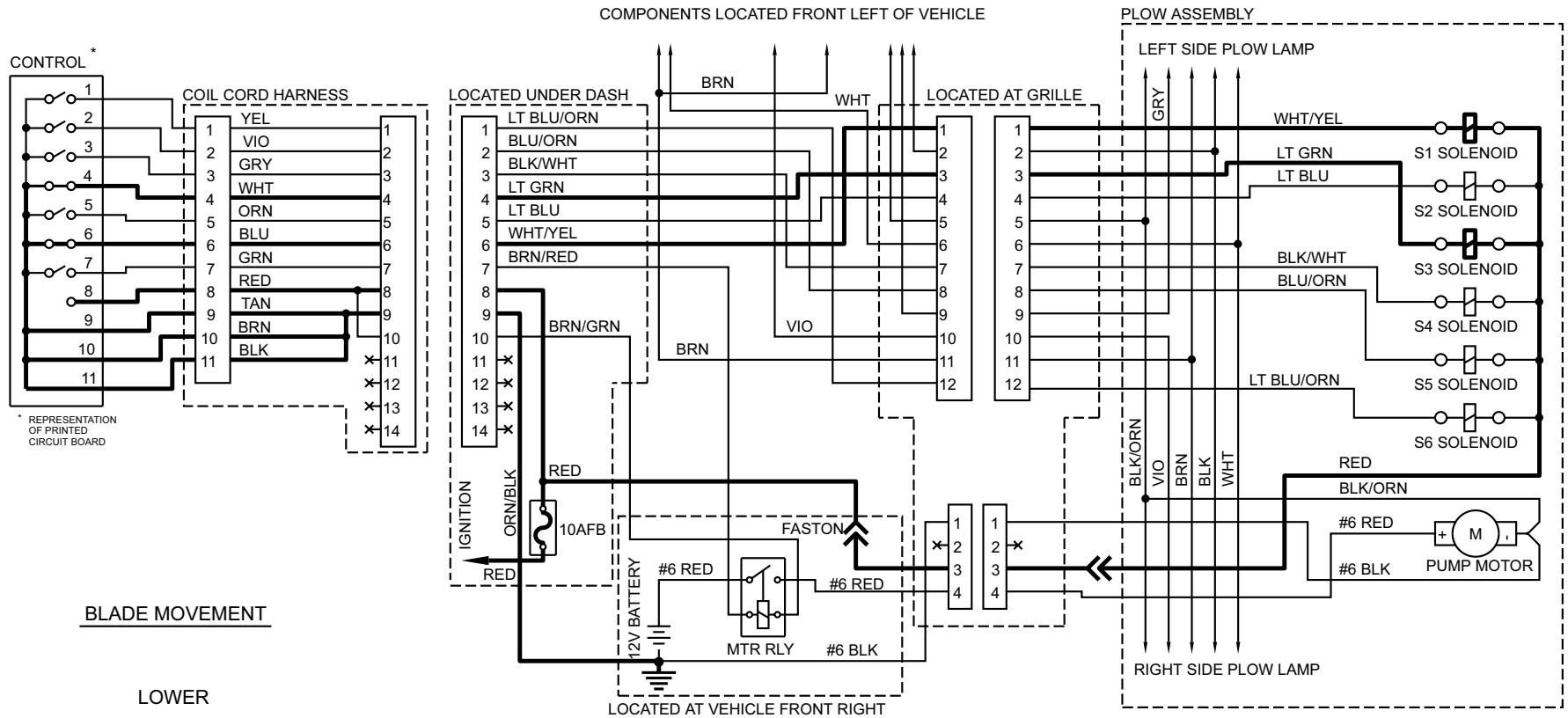

BLADE MOVEMENT

LOWER

# LOWER – HYDRAULIC

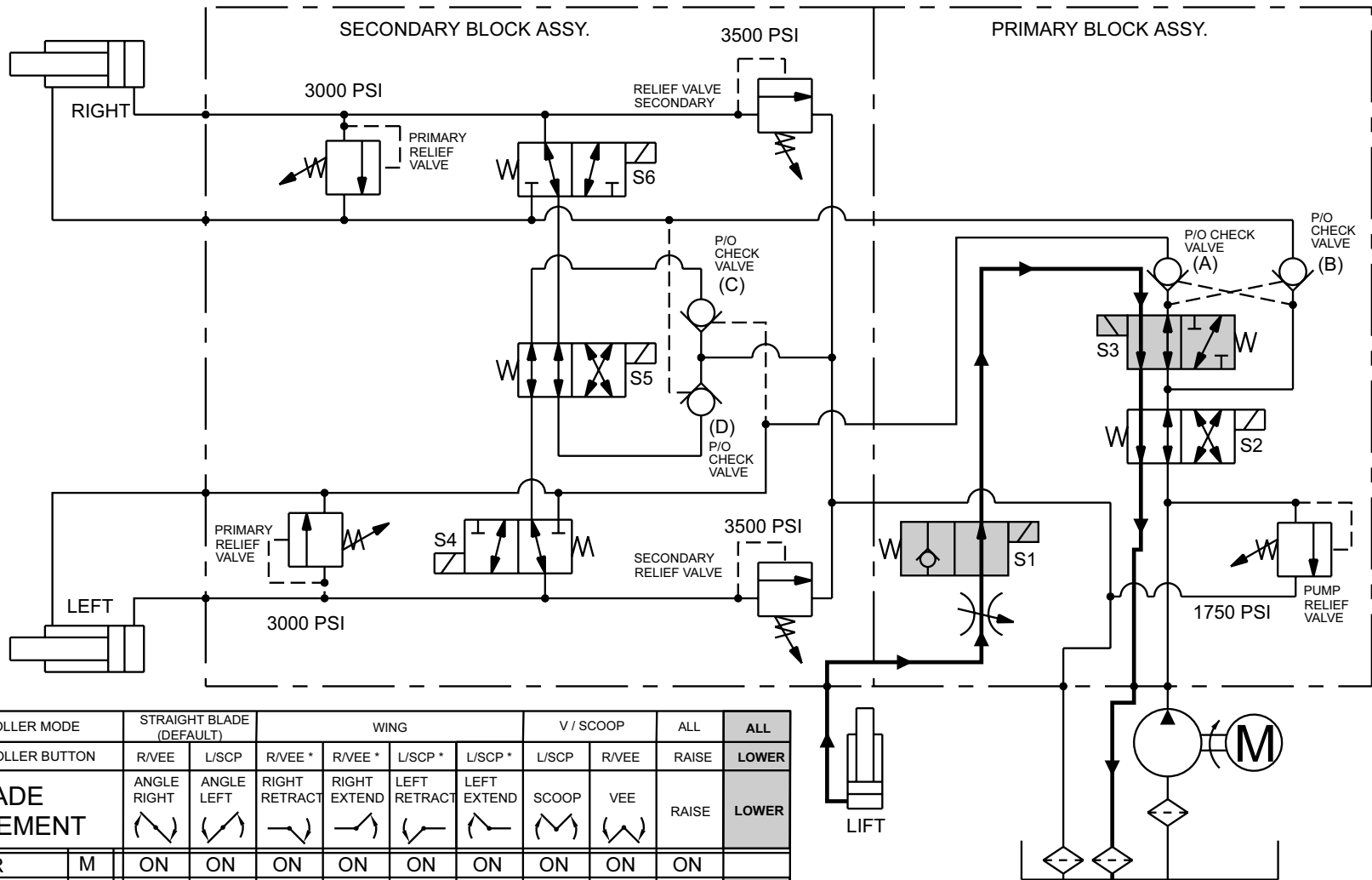

39

CONTROLLER MODE		STRAIGHT BLADE (DEFAULT)		WING				V / SCOOP		ALL	ALL
CONTROLLER BUTTON		R/VEE	L/SCP	R/VEE *	R/VEE *	L/SCP *	L/SCP *	L/SCP	R/VEE	RAISE	LOWER
<b>BLADE MOVEMENT</b>		ANGLE RIGHT	ANGLE LEFT	RIGHT RETRACT	RIGHT EXTEND	LEFT RETRACT	LEFT EXTEND	SCOOP	VEE	RAISE	LOWER
MOTOR	M	ON	ON	ON	ON	ON	ON	ON	ON	ON	ON
SV08-2004	S1										ON
SV08-40	S2		ON			ON	ON			ON	
SV08-43	S3							ON	ON	ON	ON
SV08-30	S4						ON	ON			
SV08-40	S5	ON	ON								
SV08-30	S6				ON			ON			

\* NOTE - SEE BLADE MOVEMENT TEXT FOR BUTTON OPERATION

# HOLD IN RAISE POSITION – HYDRAULIC

Blade Movement: Hold in Raised Position

Controller Mode: All Modes

Controller Button: None

System Response:

- 1) Hydraulic oil is trapped in the base end of the lift cylinder by the internal check valve in solenoid cartridge valve S1.

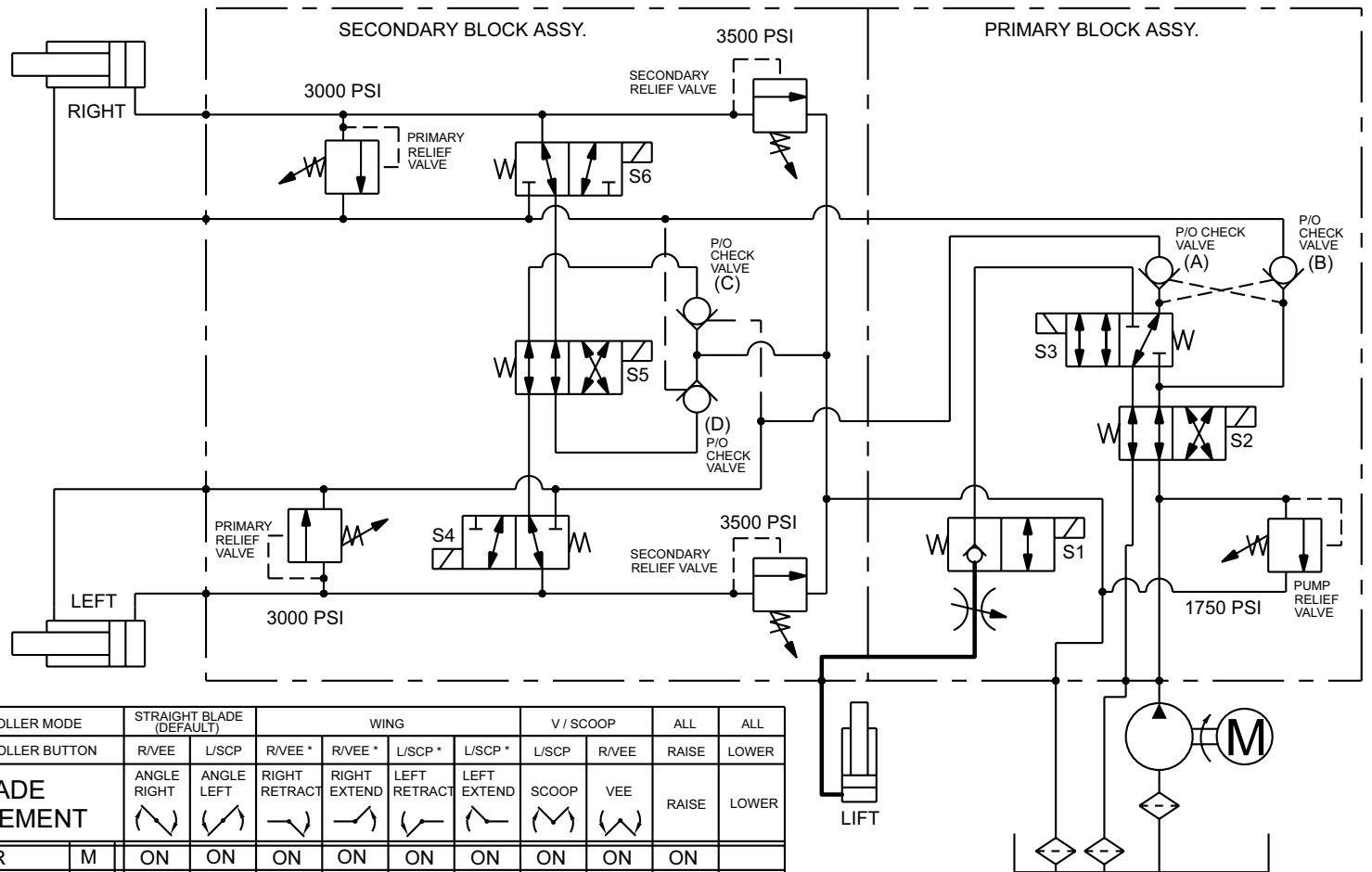

40

CONTROLLER MODE		STRAIGHT BLADE (DEFAULT)		WING				V / SCOOP		ALL	ALL
CONTROLLER BUTTON		R/VEE	L/SCP	R/VEE *	R/VEE *	L/SCP *	L/SCP *	L/SCP	R/VEE	RAISE	LOWER
<b>BLADE MOVEMENT</b>		ANGLE RIGHT	ANGLE LEFT	RIGHT RETRACT	RIGHT EXTEND	LEFT RETRACT	LEFT EXTEND	SCOOP	VEE	RAISE	LOWER
MOTOR	M	ON	ON	ON	ON	ON	ON	ON	ON	ON	
SV08-2004	S1										ON
SV08-40	S2		ON			ON	ON			ON	
SV08-43	S3							ON	ON	ON	ON
SV08-30	S4						ON	ON			
SV08-40	S5	ON	ON								
SV08-30	S6				ON			ON			

\* NOTE - SEE BLADE MOVEMENT TEXT FOR BUTTON OPERATION



# STRIKING AN OBJECT WHILE PLOWING FORWARD – HYDRAULIC

Blade Movement: Striking an Object While Plowing Forward  
 Controller Mode: All Modes  
 Controller Button: None  
 System Response:

- 1) Hydraulic oil is trapped in the base end of the right cylinder by the right primary relief valve, right secondary relief valve, and P/O check valve (D). Hydraulic oil is trapped in the base end of the left cylinder by left primary relief valve, left secondary relief valve, and P/O check valve (C).
- 2) When the plow contacts an object on the front side of the either wing, the force of the impact increases the hydraulic pressure in the base end of the cylinder. When the pressure exceeds 3000 psi, the cylinder's primary relief valve opens allowing some of the hydraulic oil to move from the base end to rod end of the same cylinder.
- 3) Due to the unequal displacement of oil between the base and rod ends of the cylinder, hydraulic pressure will continue to increase. When the pressure exceeds 3500 psi the cylinder's secondary relief valve opens allowing the remaining hydraulic oil back to the reservoir.

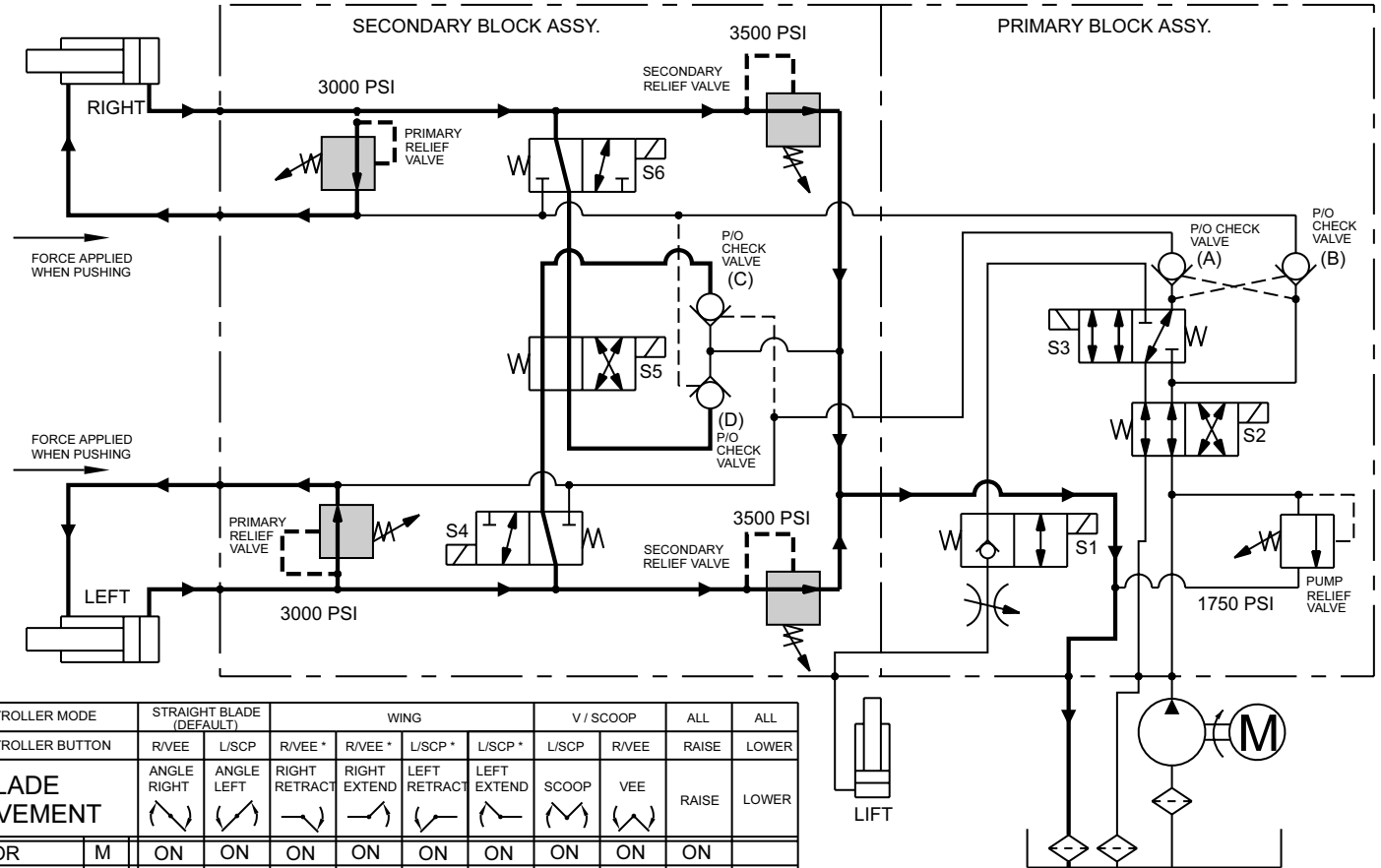

CONTROLLER MODE	STRAIGHT BLADE (DEFAULT)		WING				V / SCOOP		ALL	ALL
CONTROLLER BUTTON	R/VEE	L/SCP	R/VEE *	R/VEE *	L/SCP *	L/SCP *	L/SCP	R/VEE	RAISE	LOWER
<b>BLADE MOVEMENT</b>	ANGLE RIGHT 	ANGLE LEFT 	RIGHT RETRACT 	RIGHT EXTEND 	LEFT RETRACT 	LEFT EXTEND 	SCOOP 	VEE 	RAISE	LOWER
MOTOR	M	ON	ON	ON	ON	ON	ON	ON	ON	
SV08-2004	S1									ON
SV08-40	S2		ON			ON	ON		ON	
SV08-43	S3						ON	ON	ON	ON
SV08-30	S4					ON	ON			
SV08-40	S5	ON	ON							
SV08-30	S6				ON		ON			

\* NOTE - SEE BLADE MOVEMENT TEXT FOR BUTTON OPERATION

# STRIKING AN OBJECT WHILE BACK DRAGGING – HYDRAULIC

Blade Movement: Striking an Object While Back Dragging  
 Controller Mode: All Modes  
 Controller Button: None  
 System Response:

- Hydraulic oil is trapped in the rod end of the right cylinder by P/O check valve (B). Hydraulic oil is trapped in the rod end of the left cylinder by P/O check valve (A). **The hydraulic system does not provide pressure relief while back dragging.**

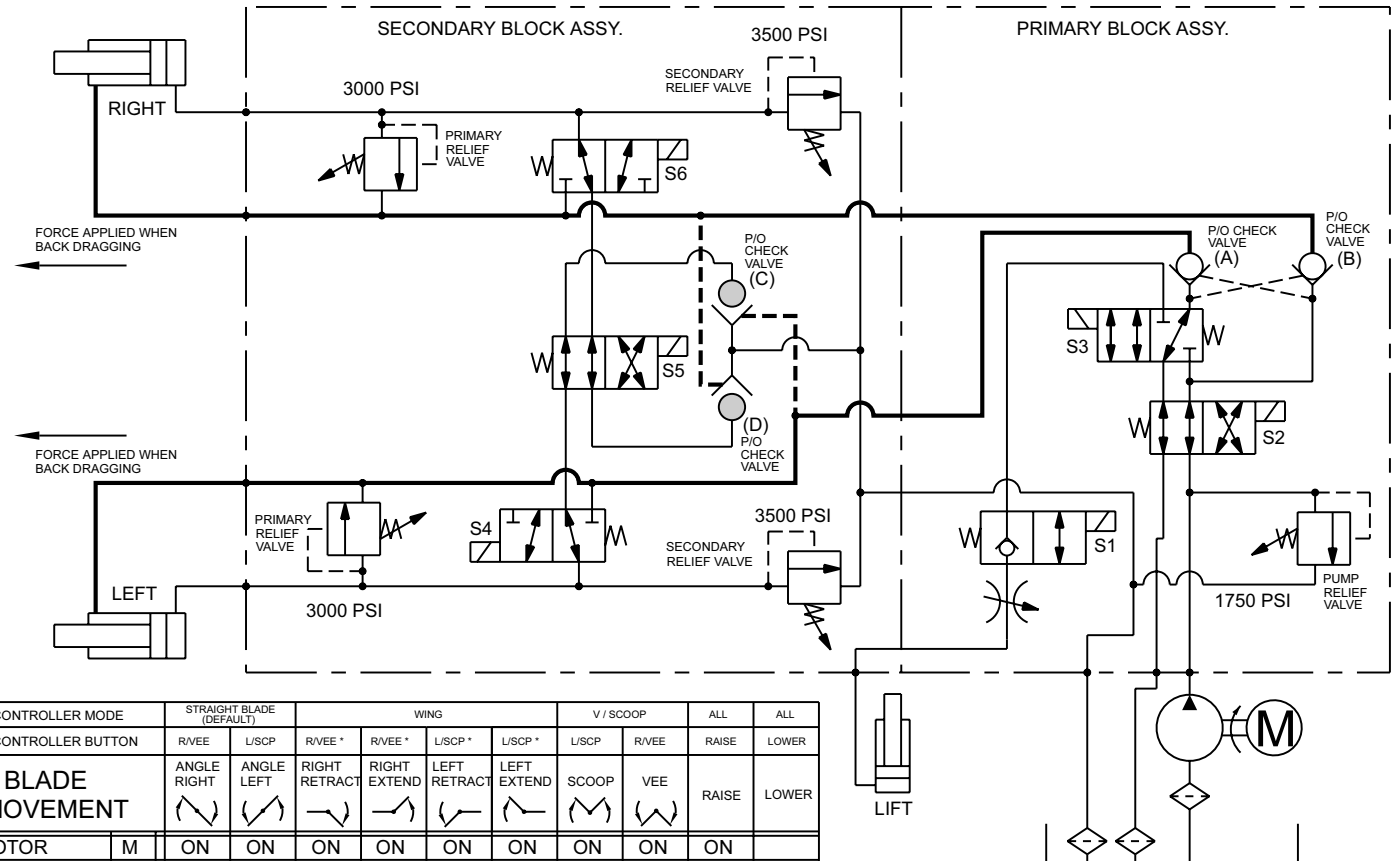

CONTROLLER MODE		STRAIGHT BLADE (DEFAULT)		WING				V / SCOOP		ALL	ALL
CONTROLLER BUTTON		R/VEE	L/SCP	R/VEE *	R/VEE *	L/SCP *	L/SCP *	L/SCP	R/VEE	RAISE	LOWER
<b>BLADE MOVEMENT</b>										RAISE	LOWER
MOTOR	M	ON	ON	ON	ON	ON	ON	ON	ON	ON	
SV08-2004	S1										ON
SV08-40	S2		ON			ON	ON			ON	
SV08-43	S3							ON	ON	ON	ON
SV08-30	S4						ON	ON			
SV08-40	S5	ON	ON								
SV08-30	S6				ON			ON			

\* NOTE - SEE BLADE MOVEMENT TEXT FOR BUTTON OPERATION

# HEADLAMPS – VEHICLE ONLY

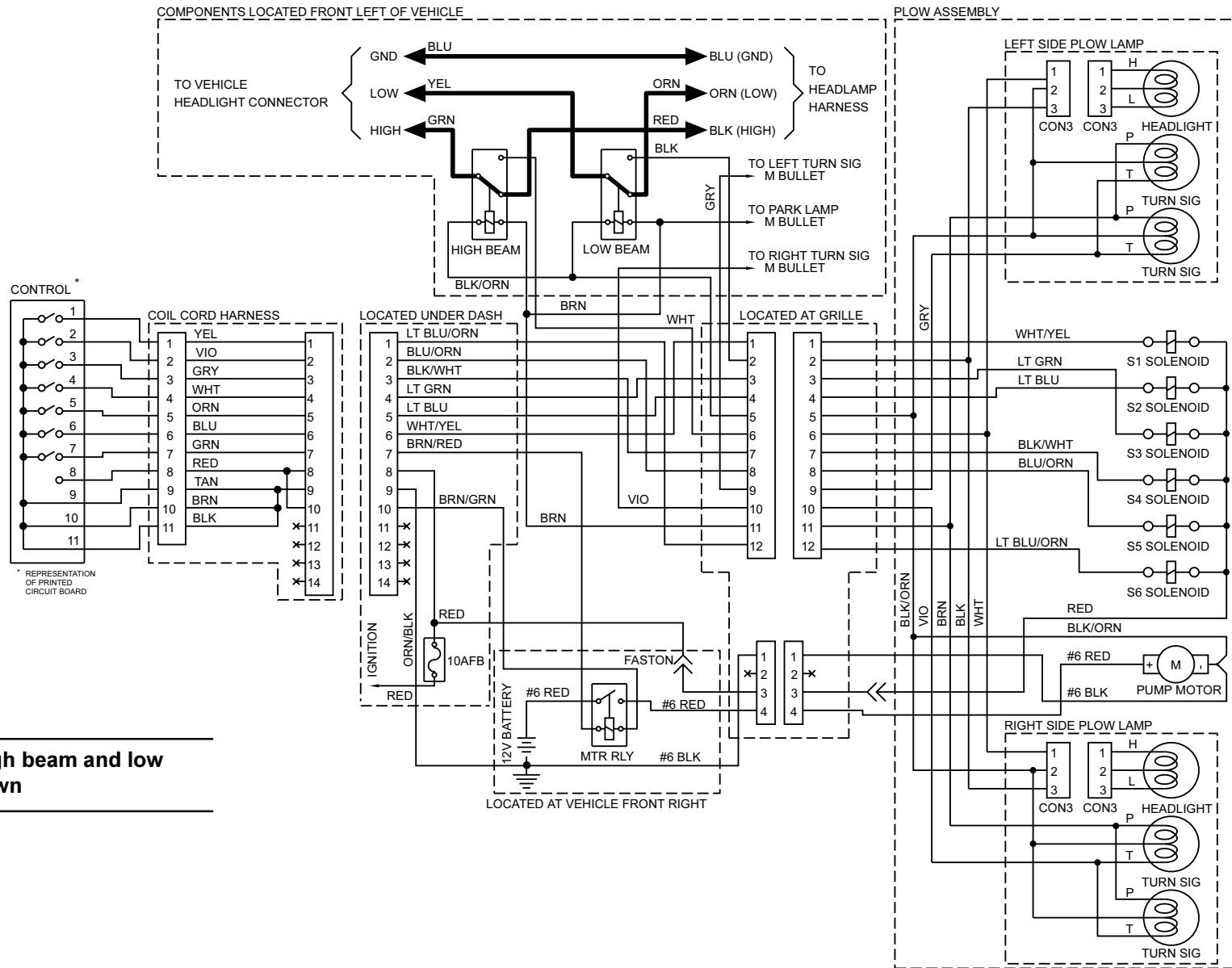

**Note: Both high beam and low beam are shown**

# HIGH BEAM HEADLAMPS WITH PLOW CONNECTED TO VEHICLE

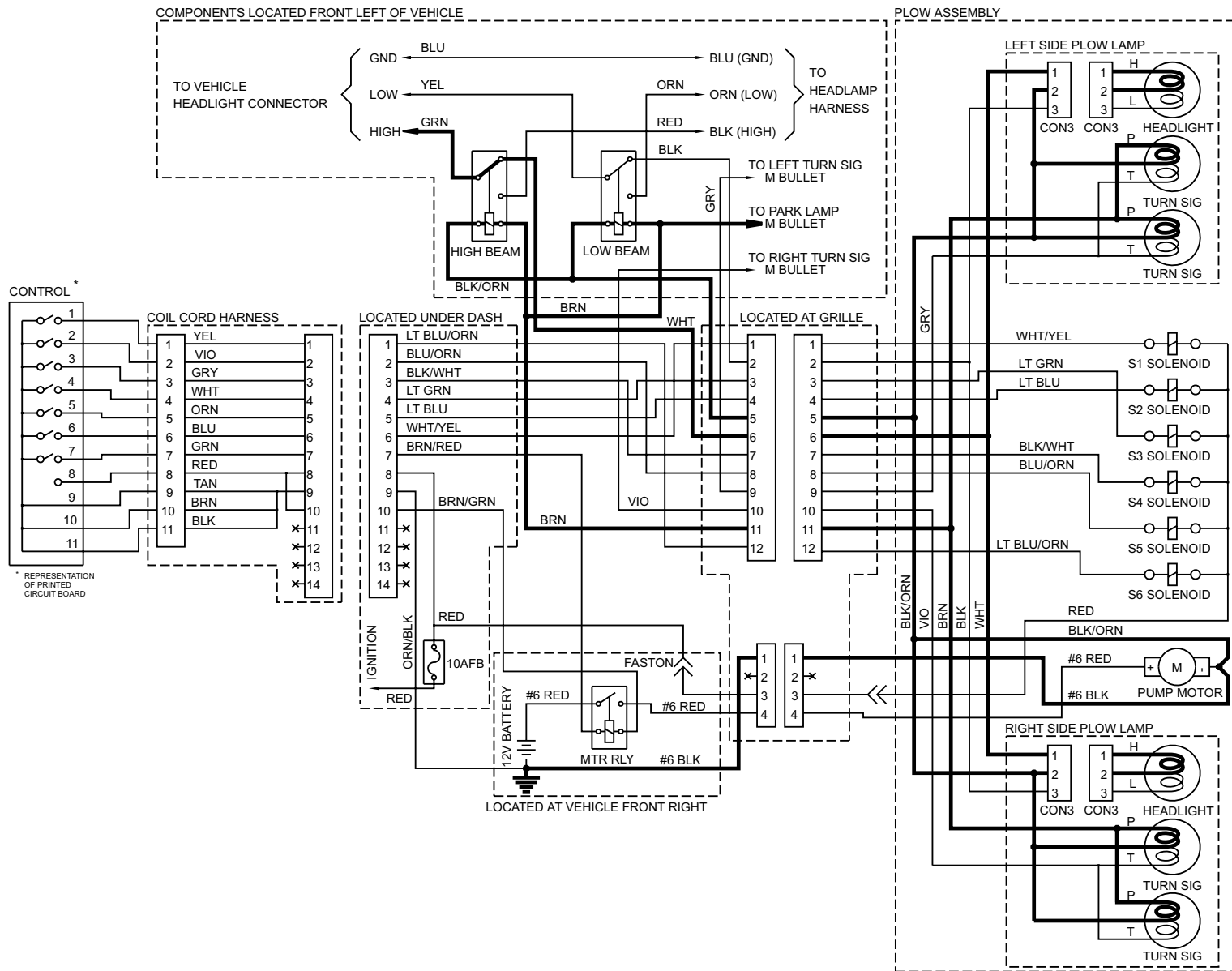

# LOW BEAM HEADLAMPS WITH PLOW CONNECTED TO VEHICLE

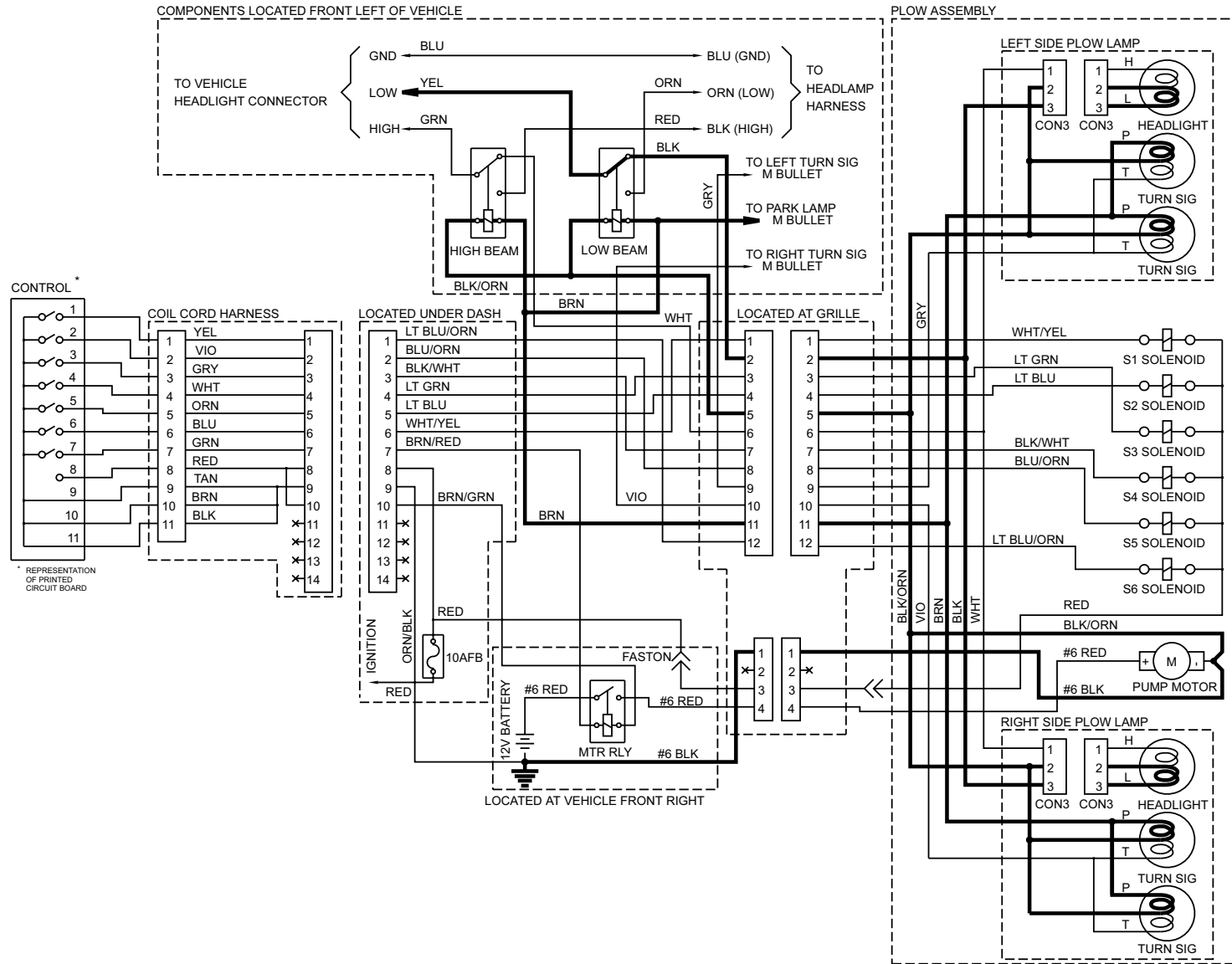

# TROUBLESHOOTING GUIDE

---

## Troubleshooting Guide Contents

General Diagnostic Table .....	47
Packing Nut Adjustment .....	50
Motor Test .....	51
Motor and Motor Relay Test Diagram .....	52
Motor Relay Test .....	53
Vehicle Harness Test – Motor Relay .....	54
Control Test .....	55
Pump Pressure Test .....	56
Solenoid Coil Activation Test .....	57
Vehicle Harness Test – Solenoid Coils .....	59
Hydraulic System Test .....	60
Relief Valve Inspection and Adjustment .....	63
Pilot Operated Check Valve Inspection .....	64
Individual Solenoid Coil Test .....	64
Solenoid Cartridge Valve Inspection .....	65
Vehicle Headlamp Test .....	66
Headlamp Test Diagram .....	67
Plow Headlamp Test .....	68
Park/Turn Lamp Test .....	69

## Introduction

This guide consists of a series of tables, diagrams, flow charts and other information. When used properly it will assist the mechanic in identifying and repairing faulty system components. Fisher highly recommends the use of the EZ-V™ Electrical Tester as a timesaving option for electrical system diagnosis. When using this tester, refer to the supplied instruction manual for proper use of the tester.

Any malfunction of the EZ-V snowplow can be categorized as either mechanical, electrical or hydraulic. Mechanical issues are generally related to the blade wings, A-frame, lift frame and mount components and are usually identified by visual inspection. Electrical and hydraulic issues can be difficult to trace to the component level and that is the purpose of this troubleshooting guide. Read and understand the Theory of Operation before attempting troubleshooting.

## How to Use the Troubleshooting Guide

Because of the relative complexity of the EZ-V snowplow electrical and hydraulic systems, many variables need to be eliminated in order to obtain workable test procedures. These variables translate into conditions listed before the tables or flow charts and must be satisfied before proceeding.

*If the listed conditions are not met, the procedure can result in inaccurate results and wasted time.*

In many cases, satisfying the listed conditions alone will solve the problem.

1. Go to the General Diagnostic Table and satisfy the ten listed conditions. These conditions must be met before proceeding into the table or to any subsequent test.
2. Locate the condition in the table which best describes the problem and check possible causes and actions in the order listed.
3. Proceed to a service procedure, another condition, or a specific

test as directed. All tests except the Hydraulic System Test use a flow chart format. To use these flow charts, first satisfy any listed conditions at the top of the page. Then begin at the upper left square and proceed as directed.

4. Follow along sequentially through the table and tests, referring to the hydraulic and electrical schematics in the Theory of Operation section and the component Identification and Location diagrams. Eventually the problem will be pinpointed at the component level.

## Electrical Testing

Read and understand the section describing electrical circuit operation in the Theory of Operation section. A simple 12V test light with a ground lead can be used for circuit testing. When directed to check for 12 volts (12V), ground the test lamp lead and probe the terminal. When asked to check for ground, attach the test lamp lead to +12V and probe the terminal. Note that 12V is a nominal value. If using a voltmeter, actual voltage will vary with the vehicle and presence of loads in tested circuits.

# GENERAL DIAGNOSTIC TABLE

Before using this General Diagnostic Table, or performing any tests, you must verify the following conditions:

1. Snowplow is attached to vehicle and all harnesses are connected.
2. Harness connector pins and terminals are free of corrosion and coated with dielectric grease, insuring good connections.
3. Vehicle battery and charging system are in good condition and battery connections are clean and tight.

**⚠ CAUTION**

**Do not mix different types of hydraulic fluid. Some fluids are not compatible and may cause performance problems and product damage.**

4. Hydraulic reservoir is filled to filler plug level with recommended fluid, when plow is in "vee" position and lift cylinder is fully

retracted. See Product Specifications.

5. There are no oil leaks from hoses, fittings, cylinders or the hydraulic unit.
6. All built up snow and ice is removed from the snowplow.
7. Vehicle harness wires are correctly installed in the 14 pin connector, located in the cab.

8. 10 amp fuse in vehicle harness is good.
9. Ignition is turned on or engine is running.
10. The control is connected in the cab and turned on.

**Note: Do not use a straight blade control with the adapter cable for these tests.**

**14-Pin Connector**

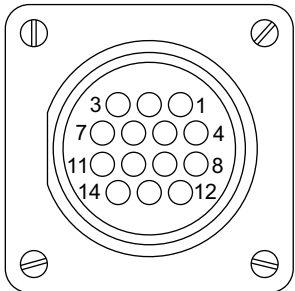

Wire Color	Pin No.
Light Blue With Orange Stripe	1
Blue With Orange Stripe	2
Black With White Stripe	3
Light Green	4
Light Blue	5
White With Yellow Stripe	6
Brown With Red Stripe	7
Red	8
Orange With Black Stripe	9
Brown With Green Stripe	10

## GENERAL DIAGNOSTIC TABLE

CONDITION	POSSIBLE CAUSE	ACTION
Motor does not run for any requested function.	Poor connections in vehicle or snowplow battery cables.	Clean and re-establish connections.
	Motor worn or damaged or pump seized.	Go to Motor Test.
	Motor relay inoperative.	Go to Motor Relay Test.
	Fault in vehicle wiring harness.	Go to Vehicle Harness Test - Motor Relay.
	Faulty controller.	Go to Control Test.
Motor runs continuously.	Motor relay sticking or always energized.	Go to Motor Relay Test.
	Fault in vehicle harness wiring.	Go to Vehicle Harness Test - Motor Relay.
	Faulty controller.	Go to Control Test.
Snowplow won't raise—motor runs.	Lift ram packing nut too tight.	Adjust lift ram packing nut.
	Clogged pump filter (all functions are affected).	Clean or replace filter, flush reservoir.
	Worn or damaged pump.	Go to Pump Pressure Test.
	Solenoid valve coils not energizing properly.	Go to Solenoid Coil Activation Test.
	Hydraulic system malfunction.	Go to Hydraulic System Test.
Snowplow raises slowly or partially—motor runs.	Lift ram packing nut too tight.	Adjust lift ram packing nut.
	Clogged pump filter (all functions are affected).	Clean or replace filter, flush reservoir.
	Worn or damaged pump.	Go to Pump Pressure Test.
In <i>straight blade</i> mode, snowplow angles slowly or partially -or- In <i>wing</i> mode, wings move slowly or partially—motor runs.	Air in angle cylinders.	Cycle wings stop to stop to remove air.
	Relief valves damaged or out of adjustment.	Go to Relief Valve Inspection and Adjustment.
	Pump filter clogged (all functions are affected).	Clean or replace filter, flush reservoir.
	Worn or damaged pump.	Go to Pump Pressure Test.
	Solenoid valve coils not activating properly.	Go to Solenoid Coil Activation Test.
	Hydraulic system malfunction.	Go to Hydraulic System Test.
	Angle cylinders damaged or bypassing internally.	Rebuild or replace angle cylinder.
Snowplow will not lower or lowers slowly, or won't float.	Lift cylinder packing nut too tight.	Adjust lift cylinder packing nut.
	Solenoid valve coils not activating properly.	Go to Solenoid Coil Activation Test.
	Hydraulic system malfunction.	Go to Hydraulic System Test.
Snowplow lowers by itself or won't stay in raised position.	Solenoid valve coils not activating properly.	Go to Solenoid Coil Activation Test.
	Hydraulic system malfunction.	Go to Hydraulic System Test.



## GENERAL DIAGNOSTIC TABLE

CONDITION	POSSIBLE CAUSE	ACTION
Wings will not lock hydraulically or hold position.	Air in angle cylinders.	Cycle wings stop to stop to remove air.
	Relief valves damaged or out of adjustment.	Go to Relief Valve Inspection & Adjustment.
	P/O check valve stuck open	Go to P/O Check Valve Inspection.
	Solenoid coils not activating properly.	Go to Solenoid Coil Activation Test.
	Hydraulic system malfunction.	Go to Hydraulic System Test.
	Angle cylinders damaged or leaking internally.	Repair or replace angle cylinders.
Plow does not perform the selected function or performs a different function.	Hydraulic hose routing incorrect.	Verify correct hose installation. See Hose Routing Diagram.
	Solenoid valve coils not energizing properly.	Go to Solenoid Coil Activation Test.
	Hydraulic system malfunction.	Go to Hydraulic System Test.
Vehicle harness 10 amp fuse blows.	Red wire in plow harness going to solenoid valve coils is shorted to ground.	Repair wire or replace plow harness.
	Red wire in vehicle harness going to terminal 3 of the vehicle battery connector is shorted to ground.	Repair wire or replace harness.
	Red wire from fuse to terminal 8 of the 14-pin connector is shorted to ground.	Repair wire or replace harness.
	Brown/green wire in vehicle harness going to motor relay primary is shorted to ground.	Repair wire or replace harness.
	Control fault.	Go to Control Test.
Control F1 fuse blows.	Motor relay primary shorted internally.	Replace motor relay.
	Solenoid valve coil S1, S2 or S3 shorted internally.	Go to Individual Coil Test.
Control F2 fuse blows.	Solenoid valve coil S4, S5 or S6 shorted internally.	Go to Individual Coil Test.
Vehicle accessory fuse blows.	Circuit overloaded.	Consult vehicle owner's manual for correct application of aftermarket electrical loads.
Excessive load on vehicle electrical system while using snowplow.	Lift cylinder packing nut too tight.	Adjust lift cylinder packing nut.
	Worn or damaged motor or pump.	Go to Pump Pressure Test.
Snowplow headlamps operate irregularly or not at all – snowplow attached.  -or- Vehicle headlamps operate irregularly or not at all – snowplow removed.	Burnt out bulbs or corroded sockets.	Replace bulbs, clean contacts.
	Wires improperly connected to relays.	Review and correct wire installation. See Headlamp Test Diagram.
	Relays inoperative.	Go to Plow Headlamp Test or Vehicle Headlamp Test.

## GENERAL DIAGNOSTIC TABLE

CONDITION	POSSIBLE CAUSE	ACTION
Vehicle daytime running lamps (DRLs) do not work – snowplow removed.	Parking brake on.	Fully release parking brake.
	Power in DRL circuit has been interrupted.	Turn lamp and/or ignition switch on and off to cycle the DRL circuitry.
	No output from DRL module.	Repair vehicle electrical system.

## PACKING NUT ADJUSTMENT

**Note:** This adjustment applies to the lift cylinder only. Angle cylinders use gland nuts which are torqued to specifications.

Periodically verify the lift cylinder packing nut is tight. If the packing nut is loose or leakage appears when raising the plow, tighten the packing nut 1/4 turn maximum after you feel the packing nut contact the packing.

### **⚠ CAUTION**

**Do not overtighten the packing nut. Over-tightening affects the operation and life of the packing.**

Packings not used for a period of time may show signs of oil weep. This should stop after use.

**Note:** A small amount of leakage is necessary to properly lubricate the rod.

# MOTOR TEST

---

## ⚠ WARNING

The driver shall keep bystanders clear of the blade during this test. Do not stand between the vehicle and the blade. During this test the right wing will retract. A moving or falling blade could cause personal injury.

Refer to the Motor and Motor Relay Test Diagram.

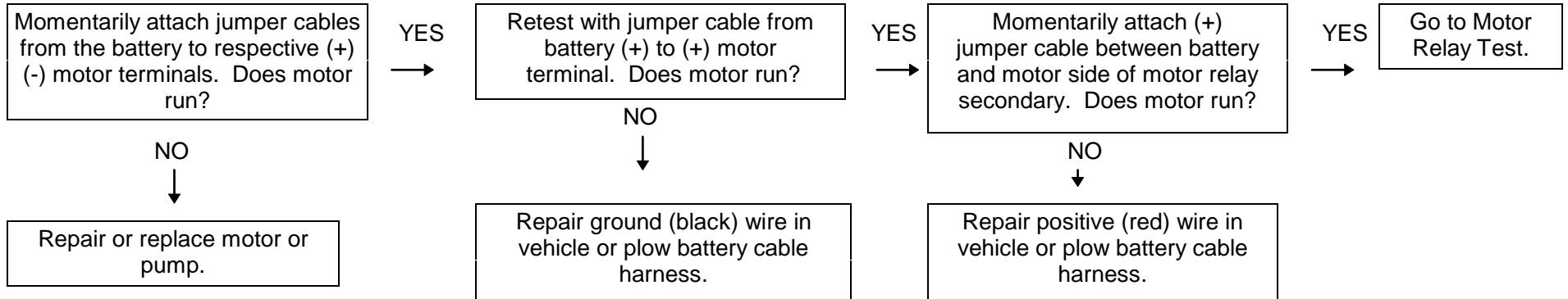

# MOTOR AND MOTOR RELAY TEST DIAGRAM

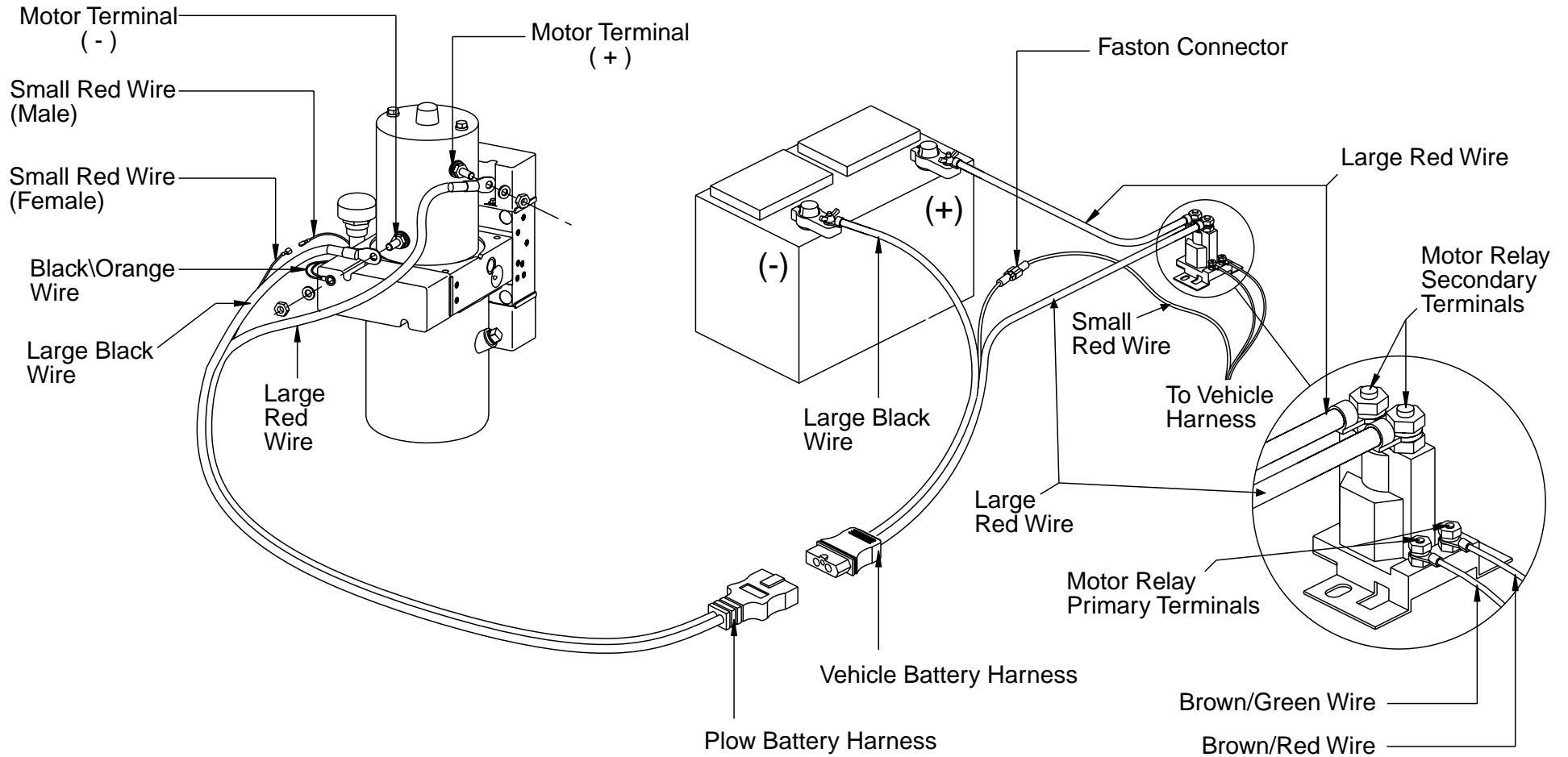

# MOTOR RELAY TEST

## ⚠ WARNING

The driver shall keep bystanders clear of the blade during this test. Do not stand between the vehicle and the blade. During this test the right wing will retract. A moving or falling blade could cause personal injury.

1. Perform motor test first to verify battery cables, motor and pump are good.
2. Refer to the Motor and Motor Relay Test Diagram.

### Motor does not run:

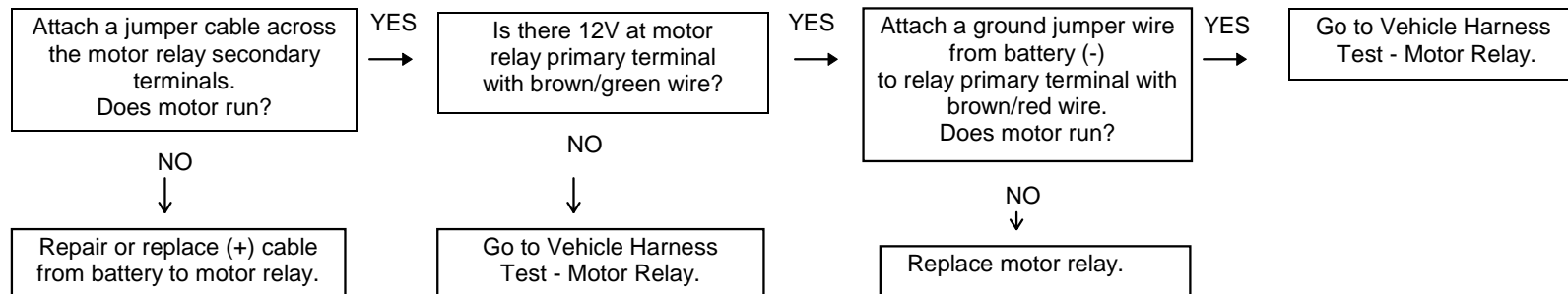

### Motor runs continuously:

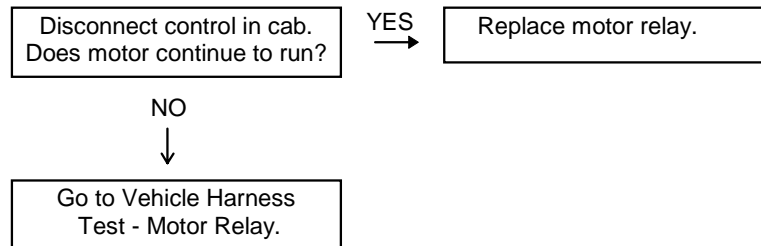

# VEHICLE HARNESS TEST - MOTOR RELAY

## ⚠ WARNING

The driver shall keep bystanders clear of the blade during this test. Do not stand between the vehicle and the blade. During this test the right wing will retract. A moving or falling blade could cause personal injury.

1. Perform the Motor Test and Motor Relay Test first.
2. Disconnect the control in the cab.
3. Refer to the 14-pin Connector diagram. Test the vehicle side of the connector in the cab as follows.

14-Pin Connector

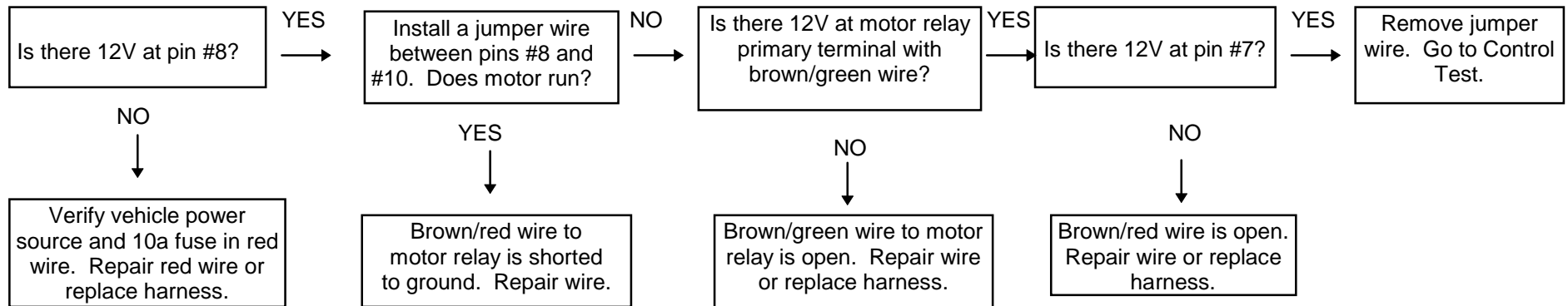
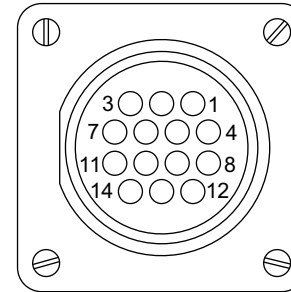

# CONTROL TEST

**⚠ CAUTION**  
**Printed circuit board (PCB) is subject to damage from static electricity. Follow instructions below to safely handle PCB.**

**To safely handle PCB:**

1. Place control on its side and remove top half of handle, leaving the PCB in lower half.
2. **Remove PCB from housing by only touching the edges of the PCB.**
3. Touch a clean finger to metal part of fuse "F2".

4. PCB is now safe to handle as long as contact with it is maintained.

**Test Procedure**

1. Disconnect the control in the cab and remove to bench.
2. Remove control handle half to access internal components.
3. Refer to diagram for fuse location.

**Note: Fuse F1 is for motor relay, S1, S2 and S3 solenoid coils. Fuse F2 is for S4, S5 and S6 solenoid coils.**

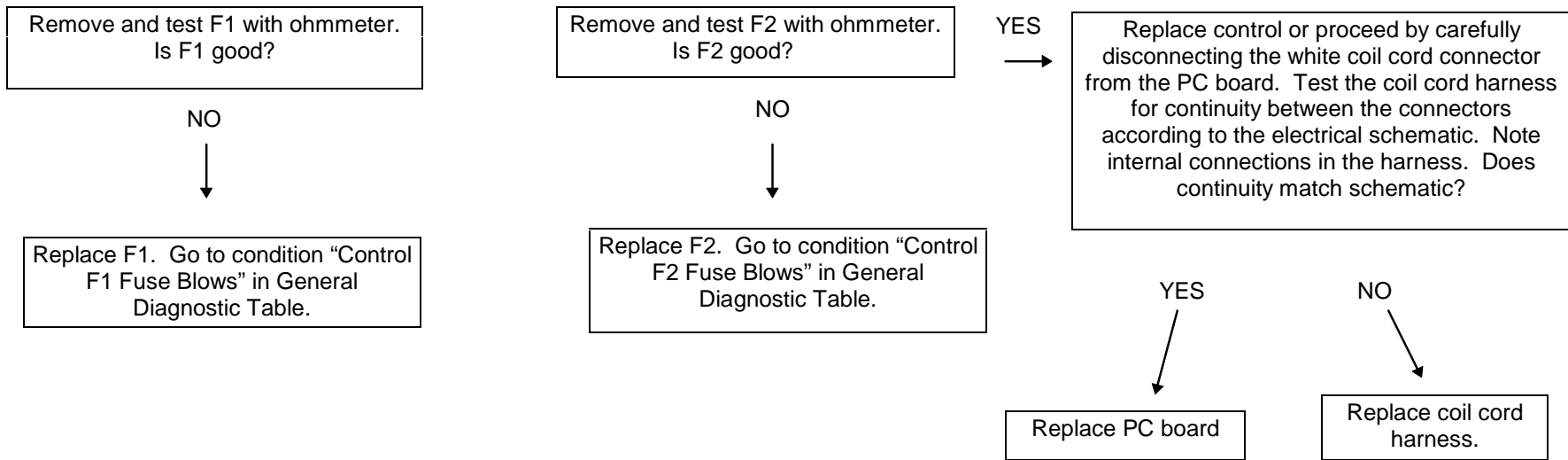
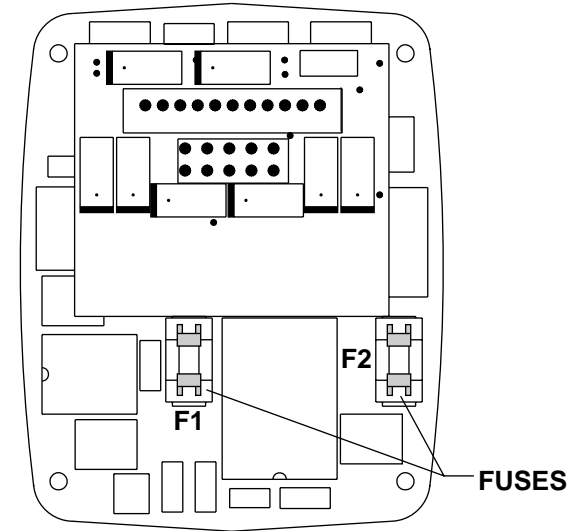

# PUMP PRESSURE TEST

1. Install a tee in-line with the lift cylinder hydraulic hose and attach a 3000 psi pressure gauge.
2. Raise the snowplow fully, hold the raise button and read the pump relief pressure.
3. Refer to Relief Valve Identification and Location for valve location.

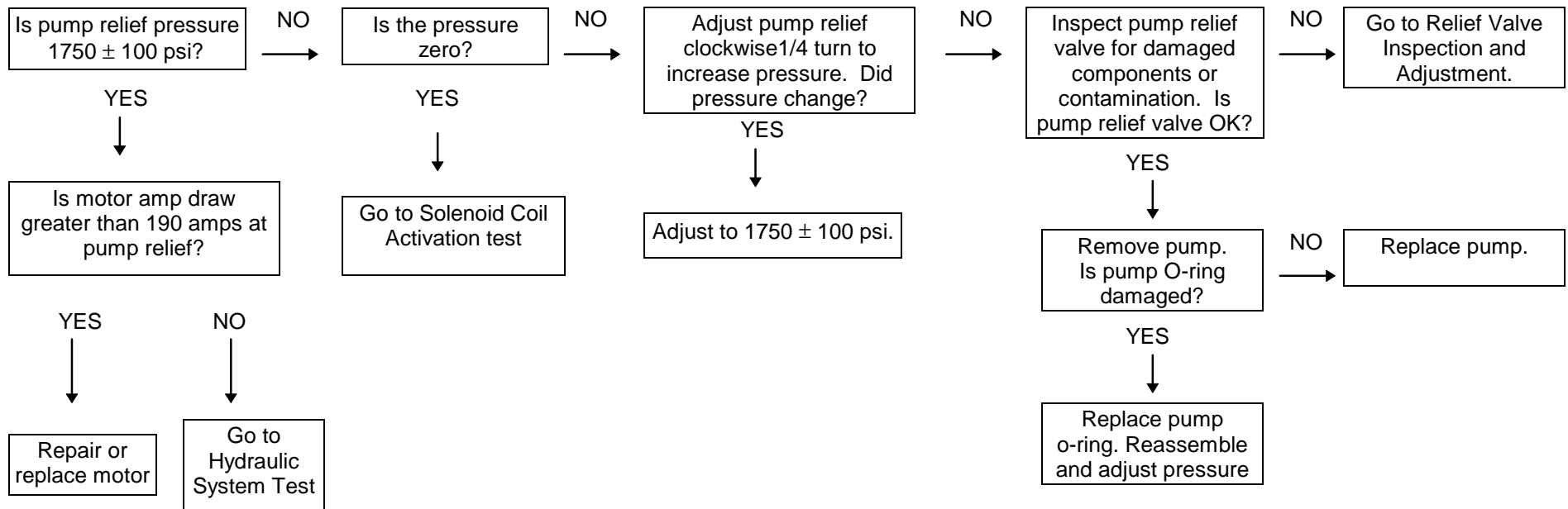



## SOLENOID COIL ACTIVATION TEST

1. Disconnect the red (+) battery cable from the motor and isolate it.
2. Remove the two lift arm pivot pins from the headgear. Place the lift arm and lift cylinder against the A-frame. This will allow access to the solenoid valve covers. Remove the solenoid cartridge covers.
3. Verify wires are properly attached to solenoid coils. Refer to table below, Electrical Schematic and Solenoid Cartridge Valve Identification and Location.
4. Activate the control for each function and check for magnetic pull at all six solenoid valve coils. Only the coils designated as "ON" in the table below should activate for each function. After noting which coils are energized, proceed to the flow chart.
5. Reassemble the headgear and lift arm after the test is complete.

Solenoid Coil	S1	S2	S3	S4	S5	S6
12-PIN GRILL CONNECTOR PIN #	1	4	3	7	8	12
14-PIN CONNECTOR PIN #	6	5	4	3	2	1
WIRE COLOR	WHITE/ YELLOW	LIGHT BLUE	LIGHT GREEN	BLACK/ WHITE	BLUE/ ORANGE	LT BLUE/ ORANGE
ANGLE RIGHT					ON	
ANGLE LEFT		ON			ON	
RIGHT RETRACT *						
RIGHT EXTEND *						ON
LEFT RETRACT *		ON				
LEFT EXTEND *		ON		ON		
SCOOP			ON	ON		ON
VEE			ON			
RAISE		ON	ON			
LOWER	ON		ON			

**\*Coils activate on every other hit of the button in wing mode, beginning with retract when wing mode is first entered.**

# SOLENOID COIL ACTIVATION TEST

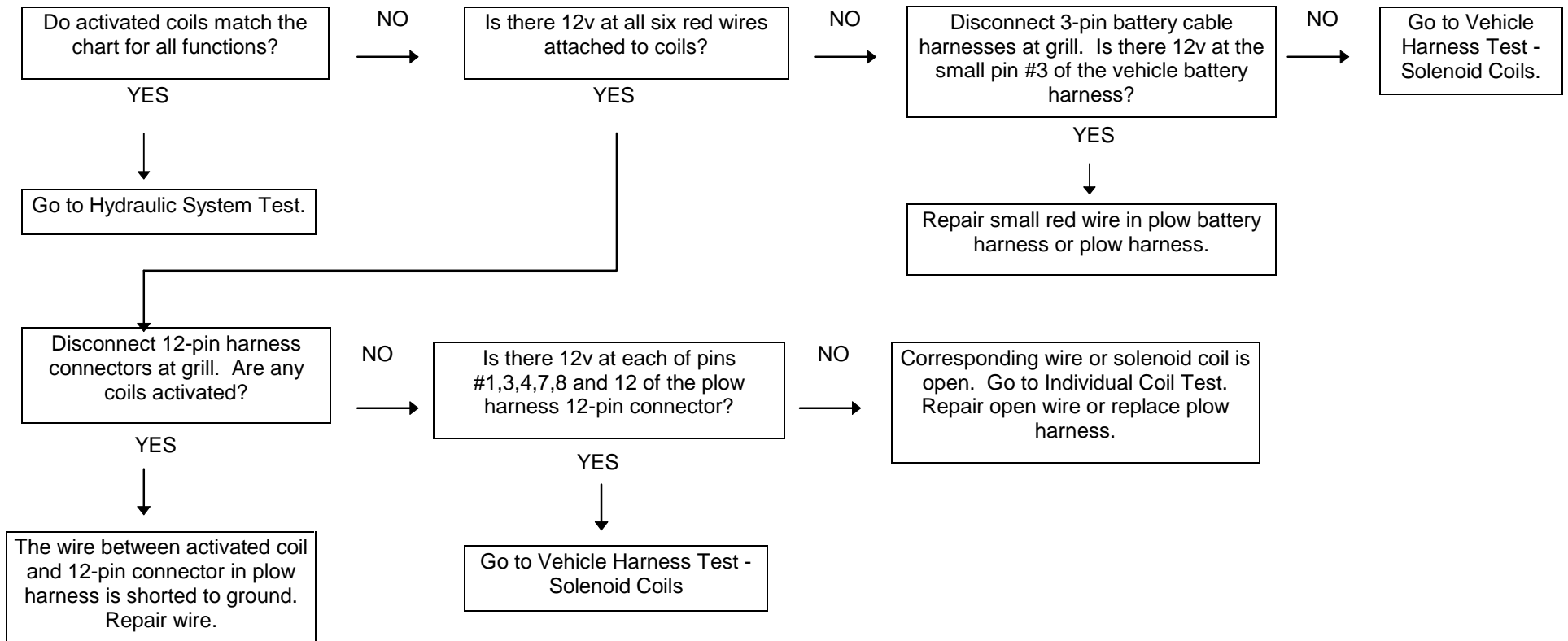

# VEHICLE HARNESS TEST — SOLENOID COILS

1. Perform solenoid coil activation test first.
2. Disconnect the red (+) battery cable from the motor and isolate it.
3. Connect all harness connectors at the grill.
4. Refer to the 14-pin Connector diagram for pin location.

**14-Pin Connector**

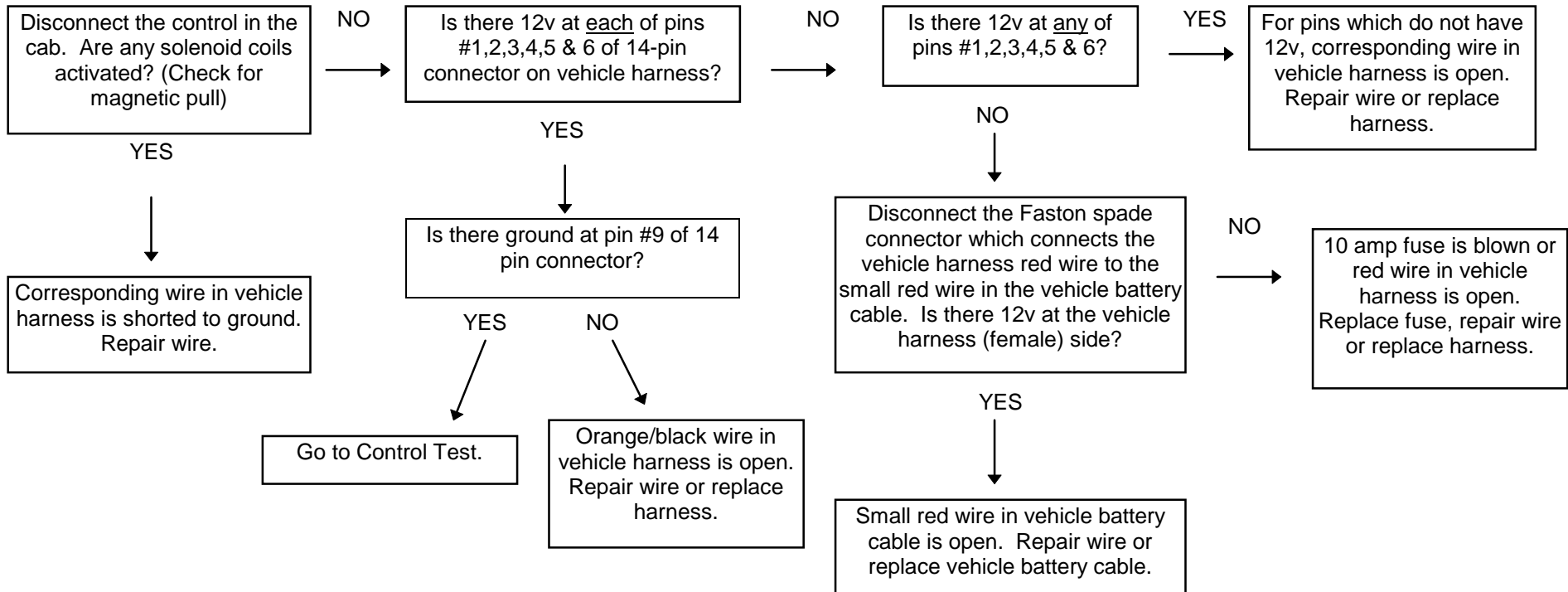
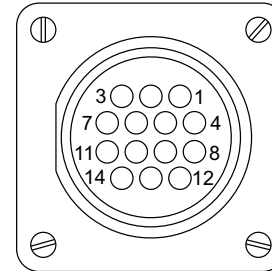

## HYDRAULIC SYSTEM TEST

This test consists of trying all the plow functions and comparing the plow reaction to the action requested in the following table. The table will pinpoint faulty solenoid valves or closed p/o check valves accurately if only one component is malfunctioning. If the plow reaction for a given function is not listed in the table, there may be relief or p/o check valves which are stuck open or contaminated, missing or damaged o-rings or backing rings

on solenoid, relief or p/o check valves, or there may be two or more faulty components. In this case, use the specific function hydraulic schematic and carefully inspect each component in the flow circuit. If contamination is evident in more than one component, the hydraulic unit, hoses and cylinders must be completely disassembled, inspected and cleaned.

1. Perform Solenoid Coil Activation Test first.
2. Verify hydraulic hose installation is correct. Refer to the Hose Routing diagram.
3. Test all of the plow functions.
4. Inspect and clean or replace the suspected component. Refer to the Hydraulic Unit Parts Diagram.

5. Refer to the sections following the table for inspection and adjustment of solenoid, cartridge valves, p/o check valves and relief valves.

**IMPORTANT:** *When testing the plow functions, be sure the control is not in "float."*

ACTION REQUESTED	PLOW REACTION	POSSIBLE CAUSE
Angle Right	• Angle Left	⇒ S2 stuck shifted
	• None	⇒ S3 stuck shifted ⇒ Check valve B closed ⇒ Check valve A closed
	• Right Extend	⇒ S6 stuck shifted
	• Right Retract	⇒ S5 not shifted
	• None	⇒ S4 stuck shifted
	Angle Left	• Angle Right
• Raise		⇒ S3 stuck shifted
• None		⇒ Check valve A closed ⇒ Check valve B closed
• Left Extend		⇒ S4 stuck shifted
• Left Retract		⇒ S5 not shifted
• None		⇒ S6 stuck shifted

# HYDRAULIC SYSTEM TEST

ACTION REQUESTED	PLOW REACTION	POSSIBLE CAUSE
Right Retract	• Left Retract	⇒ S2 stuck shifted
	• Vee	⇒ S3 stuck shifted
	• None	⇒ Check valve B closed ⇒ Check valve D closed
	• Right Extend	⇒ S6 stuck shifted
	• Angle Right	⇒ S5 stuck shifted
Right Extend	• Left Retract	⇒ S2 stuck shifted
	• Right Extend and Left Retract—wings not locked	⇒ S3 stuck shifted
	• None	⇒ Check valve B closed
	• Right Retract	⇒ S6 not shifted
Left Retract	• Right Retract	⇒ S2 not shifted
	• Raise	⇒ S3 stuck shifted
	• None	⇒ Check valve A closed ⇒ Check valve C closed
	• Left Extend	⇒ S4 stuck shifted
	• Angle Left	⇒ S5 stuck shifted
Left Extend	• Right Retract	⇒ S2 not shifted
	• Raise	⇒ S3 stuck shifted
	• None	⇒ Check valve A closed
	• Left Retract	⇒ S4 not shifted

## HYDRAULIC SYSTEM TEST

ACTION REQUESTED	PLOW REACTION	POSSIBLE CAUSE
Scoop	• Raise	⇒ S2 stuck shifted
	• Right Extend—left wing floats	⇒ S3 not shifted
	• Right Extend	⇒ Check valve A closed
	• Left Extend	⇒ Check valve B closed
	• Right Extend and Left Retract—wings not locked	⇒ S4 not shifted
	• Left Extend	⇒ S6 not shifted
Vee	• Raise	⇒ S2 stuck shifted
	• Right Retract	⇒ S3 not shifted
		⇒ Check valve A closed
		⇒ Check valve C closed
	• Left Retract	⇒ Check valve B closed
	• Left Extend and Right Retract—wings not locked	⇒ S4 stuck shifted
	• Left Retract	⇒ Check valve D closed
• None	⇒ S5 stuck shifted	
• Left Retract and Right Extend—wings not locked	⇒ S6 stuck shifted	
Raise	• Vee	⇒ S2 not shifted
	• Left Retract	⇒ S3 not shifted
	• Raises very slowly	⇒ S1 stuck shifted
Hold Raised	• Lower	⇒ S1 stuck shifted or has faulty internal check valve
Lower	• Lowers very slowly	⇒ S2 stuck shifted
	• None	⇒ S3 not shifted
		⇒ S1 not shifted

# RELIEF VALVE INSPECTION AND ADJUSTMENT

## Relief Valve Inspection

1. Remove the valve stem, ball, spacer and spring.
2. Look for broken or damaged parts, contamination or missing or damaged O-rings.
3. If OK, place ball on hard wood block, hold stem seat on ball and lightly strike stem with a hammer.

**⚠ CAUTION**  
**Be careful to strike stem squarely. You can bend stem if you do not strike it squarely.**

4. Reassemble components into manifold block. Apply a light coat of anti-seize or grease to stem threads.

## Adjustment

1. Adjust by tightening the relief valve stem as much as possible (until spring is fully compressed)
2. Back off valve stem (rotate counterclockwise) the number of turns indicated in the chart.

Relief Valve	No. of Turns Backed Off (CCW) From Fully Seated	Approximate Relief Valve Pressure (PSI)
Pump Relief	2-1/2 - 2-3/4*	1750
Right or Left Cylinder Primary Relief	1-1/2 - 1-3/4**	3000
Right or Left Cylinder Secondary Relief	1-1/4 - 1-1/2	3500

\* Install a tee in line with the lift cylinder hydraulic hose and attach a 3000 psi gauge. Read the pressure at pump relief when holding the raise function button. Adjust pump relief valve to obtain 1750+/- 100 psi.

\*\* Be certain the cylinder primary relief valve stem is backed out 1/4 turn farther than the secondary relief valve stem.

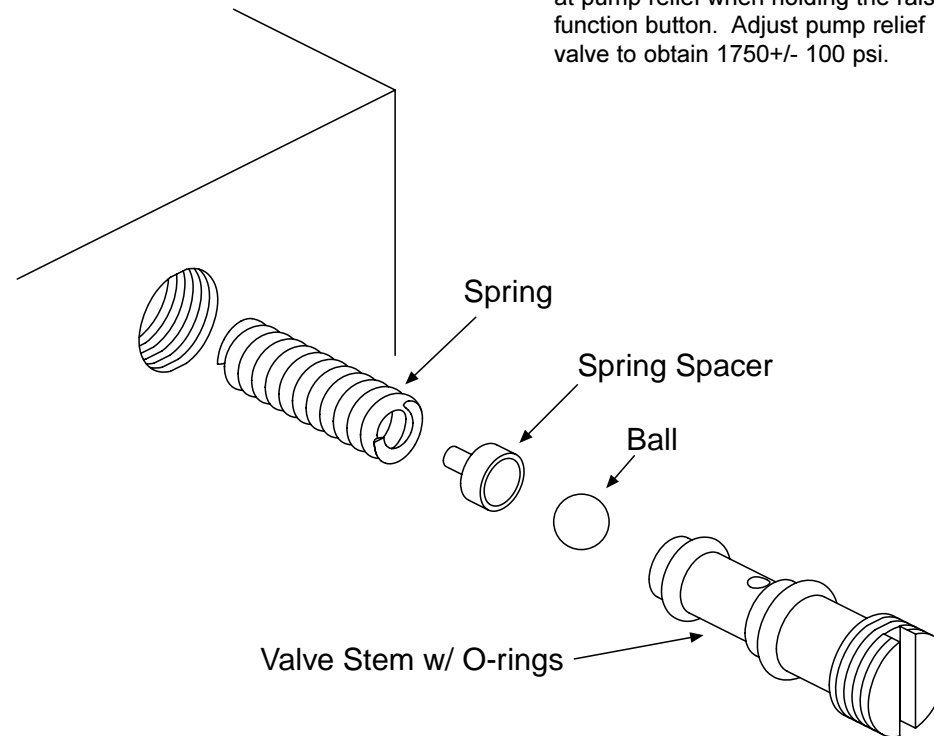

## PILOT OPERATED CHECK VALVE INSPECTION

## INDIVIDUAL SOLENOID COIL TEST

1. Remove check valve assembly from manifold block. Using miniature needle nosed pliers, remove the spool from the bore.
2. Using a plastic, aluminum or soft brass probe, push on the ball in the end of the check valve. It should move freely, then return to the closed position. If the ball sticks open or closed or binds, replace the check valve assembly. Clean, repair or replace as necessary. Be sure replacement service p/o check valve assemblies have the letter "V" stamped on the hex. Inspect the spool for signs of wear or any damage indicating it is not shifting. Look for worn or damaged O-rings and repair or replace as necessary.
3. Re-oil all O-rings and reinstall the spool by holding the stem with the miniature needle nosed pliers and carefully inserting it fully into the bore. Install the check valve assembly and torque to 120 in-lb.

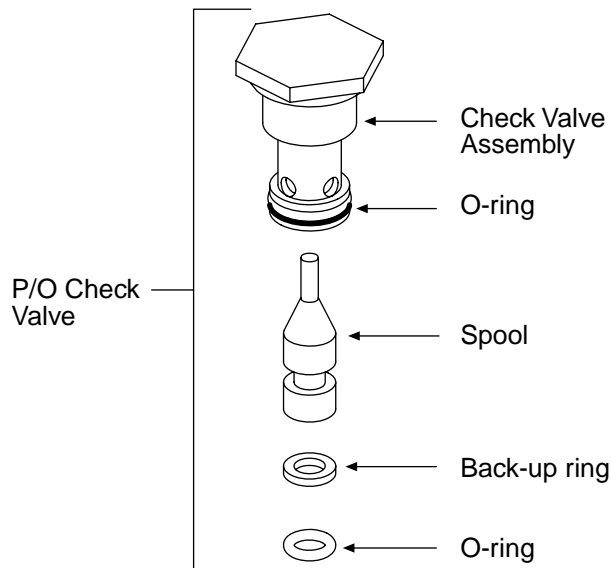

1. Remove both wires from coil terminals.
2. Attach an ohmmeter across the coil terminals.
3. A reading of approximately 7 ohms indicates the coil is OK.

---

**Note: A good coil will draw approximately 1.5 amps.**

---



## SOLENOID CARTRIDGE VALVE INSPECTION

**Note: S3, the SV08-43 cartridge valve is identical to the S2 and S5 SV08-40 cartridge valves in physical appearance. These two valves function differently internally and cannot be interchanged. The only way to tell them apart is by looking for the stamping “SV08-43” or “SV08-40” on the side of the hex.**

1. Remove coils from cartridge valves and remove cartridge valves from manifold. Look for visible contamination or damaged seals. Check for stuck spools with a plastic, aluminum, or soft brass probe by pushing on the spring loaded internal spool from the end of the valve. The spool should move freely through its entire travel.

**Note: Using probe to move spool may shear contamination which was affecting spool movement.**

2. Bench test the cartridge valve by installing a coil on the stem and applying 12V. Watch through the side ports for internal spool travel.

If the cartridge valve spool is stuck or its travel is restricted, replace the cartridge. If the cartridge valve appears OK, clean it with parts cleaning solvent and dry with compressed air, being careful not to damage the seals. Check the spool travel again in case any internal contaminants were dislodged during cleaning. Re-oil the cartridge valve seals and o-rings and reinstall the cartridge valve, torquing to 10 ft-lb. Install the coils and torque retaining nuts to 4-5 ft-lb.

**Note: If contamination is seen in more than one component, it can be reasonably assumed that the entire system is contaminated and in order to perform a proper repair, the entire hydraulic unit must be disassembled and cleaned. The hoses and cylinders must also be disassembled and cleaned.**

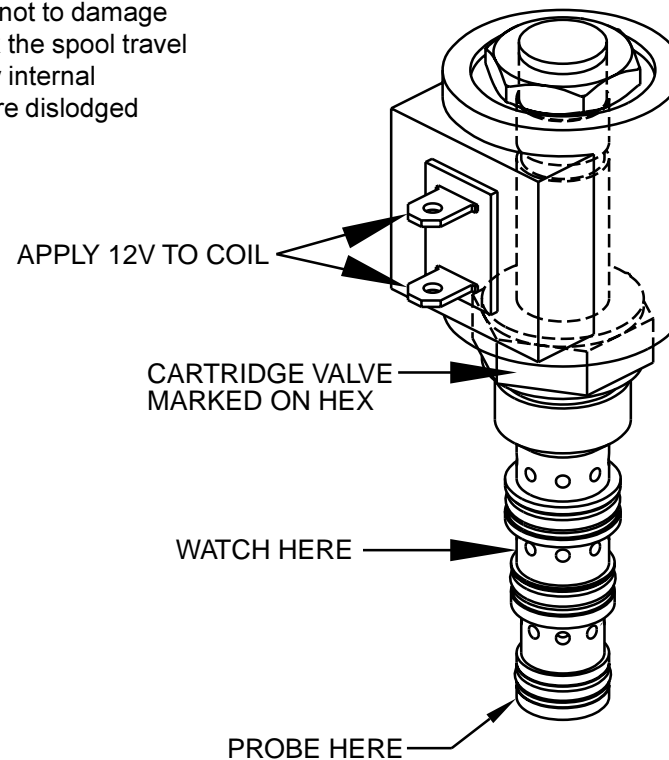

# VEHICLE HEADLAMP TEST

1. Verify correct wire installation to relays. See the Headlamp Test Diagram.
2. Turn ignition and headlight switch on.
3. Disconnect all harnesses at the grill.
4. All bulbs must be good.

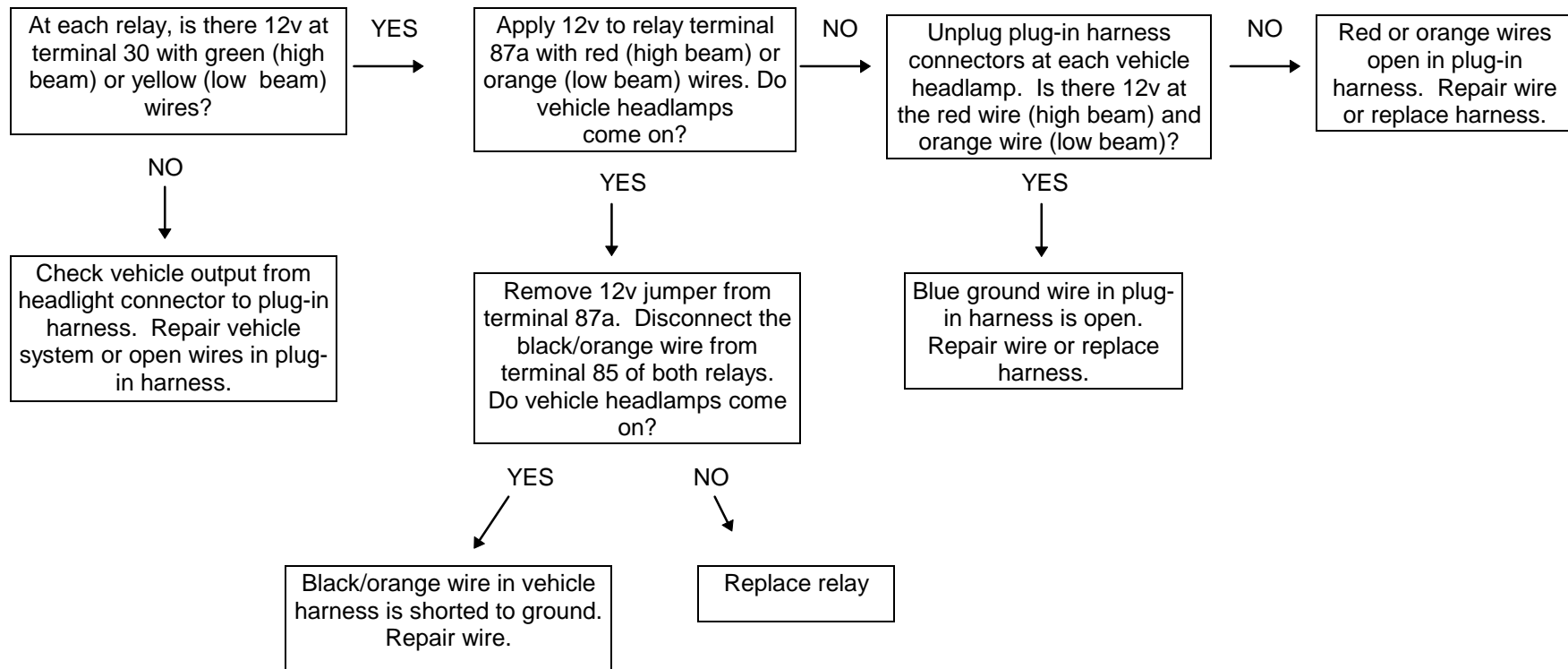

# HEADLAMP TEST DIAGRAM

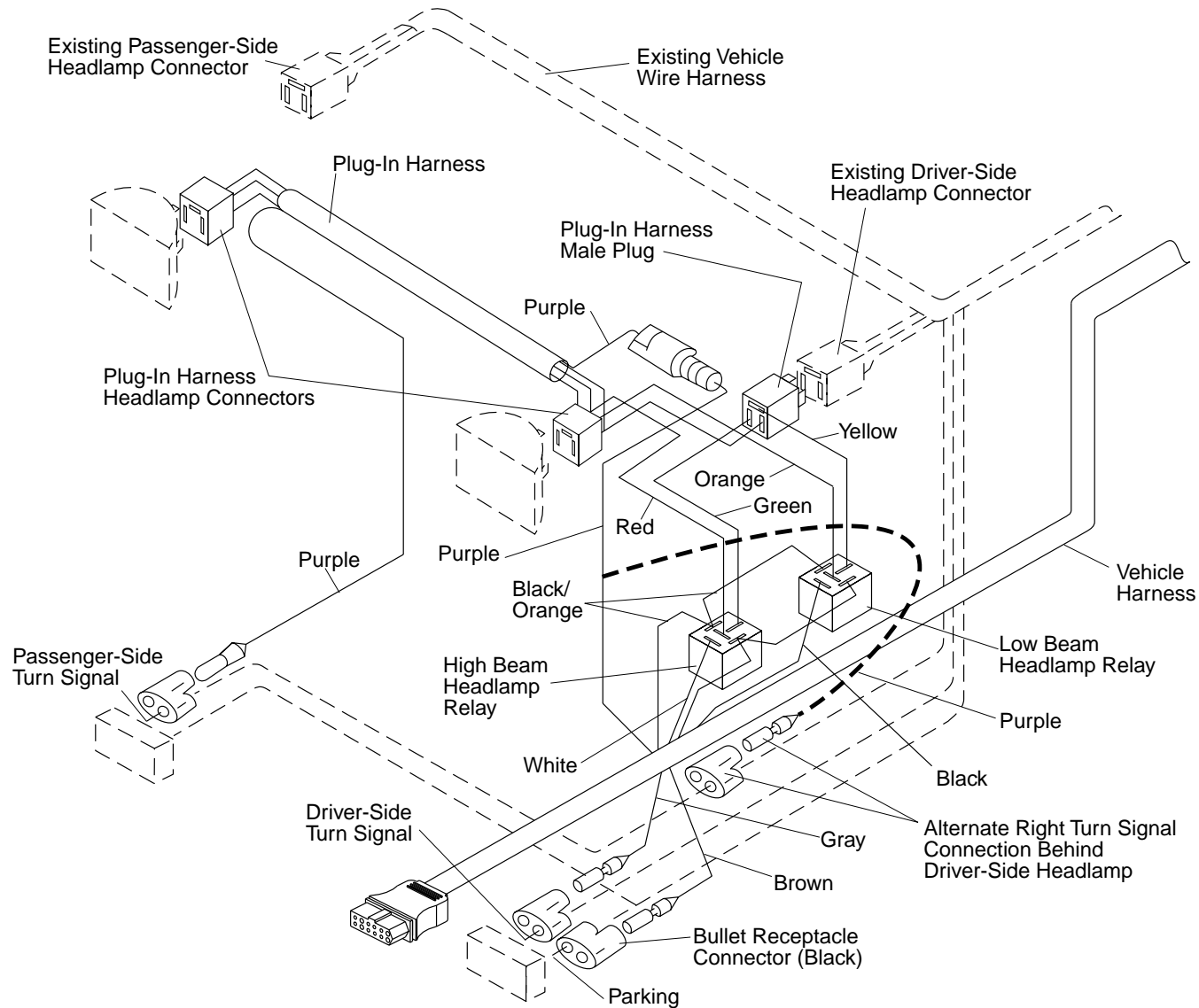

## Headlamp Relay Wiring Diagram

Low Beam Headlamp Relay

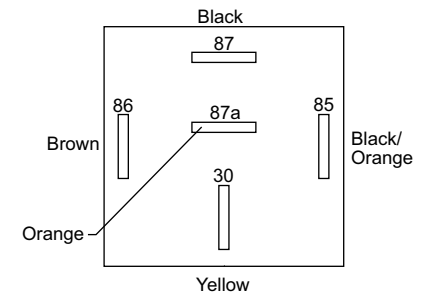

High Beam Headlamp Relay

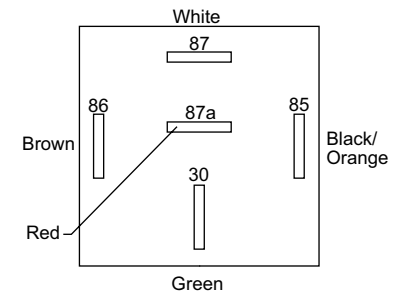

# PLOW HEADLAMP TEST

1. Verify correct wire installation to the headlamp relays
2. All bulbs must be good.
3. Connect all harnesses at the grill.
4. Turn vehicle headlamp switch on. For vehicles with Daytime Running Lamps (DRLs), turn ignition on. DRL equipped vehicles have a pink wire instead of a brown wire on relay terminal 86.
5. Refer to the Electrical Schematic, Headlamp Test diagram and 12-Pin Connector diagram.

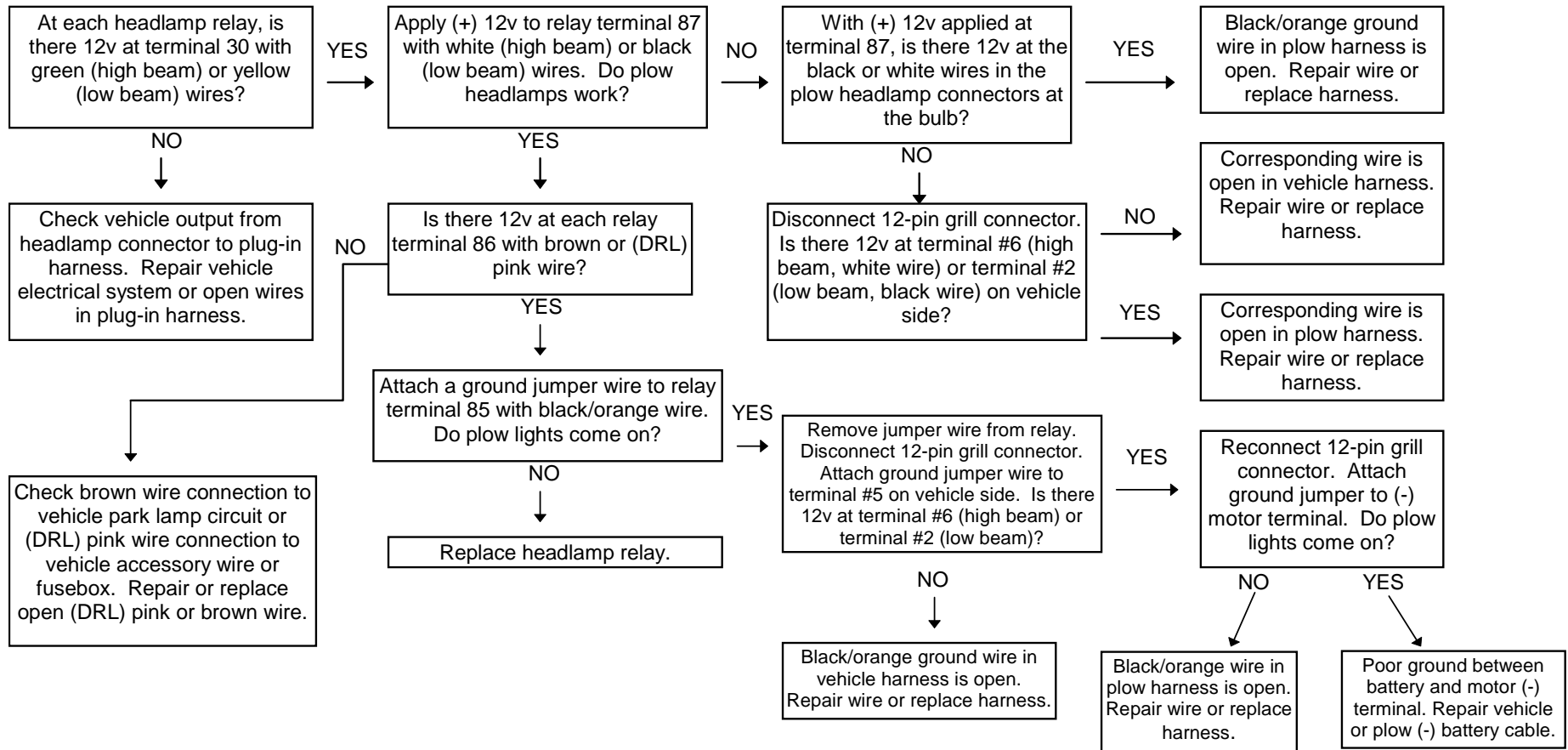
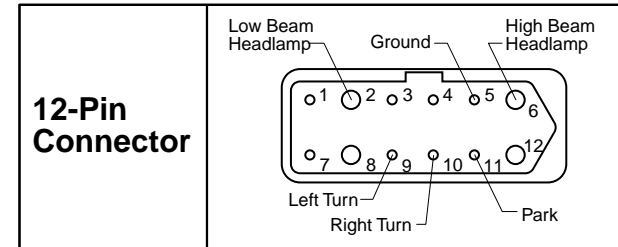

# PARK/TURN LAMP TEST

1. Verify plow park/turn (P/T) bulbs and contacts are good.
2. Turn parking lamps and ignition on.
3. Connect all harnesses at the grill.
4. Refer to the 12-Pin Connector diagram.

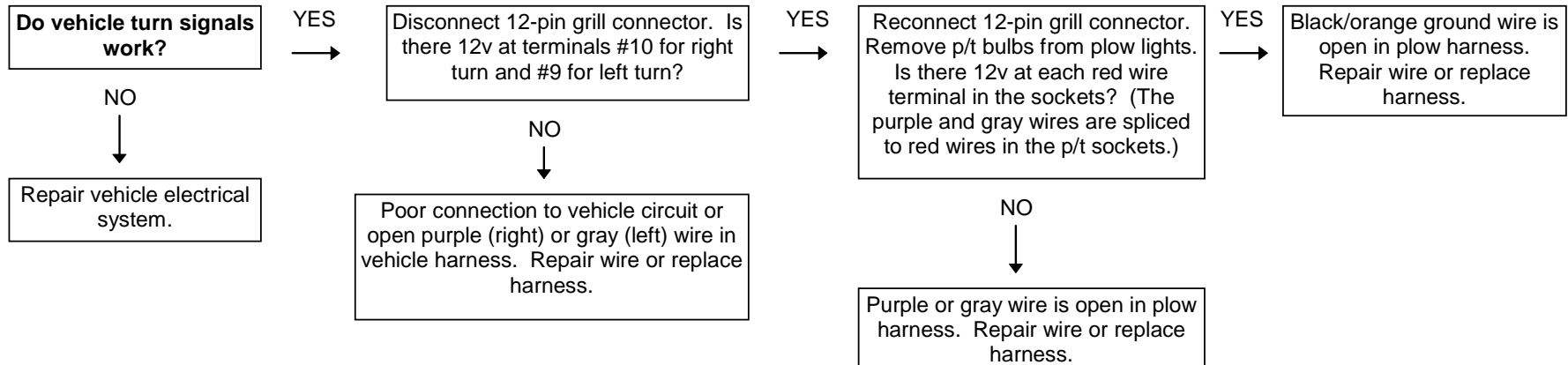
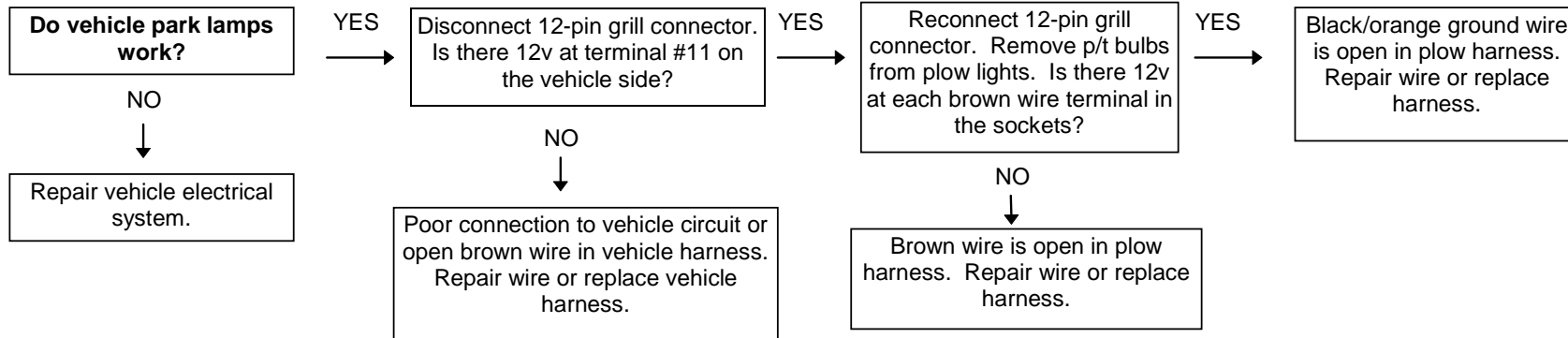
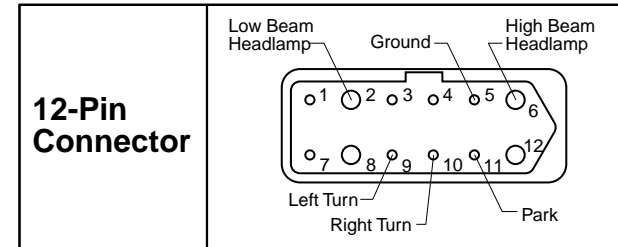

## REMOVABLE SPRING TOOL

To Replace A Spring On The Blade, Follow The Instructions Below.

### ⚠ CAUTION

Servicing the trip springs without special tools and knowledge could result in personal injury. See your authorized Fisher outlet for service.

1. Insert the threaded rod in through the hole in the channel weldment. Be sure the threaded hole in the tab on the rod is nearest to the channel.
2. Place the assembly on to the top anchor above the spring as illustrated. Be sure to place the

spring bar in between the tabs on the rod. Insert the 1/2 x 1-1/2" Gr. 5 cap screw through the outside tab, through the hole in the spring bar, and tighten into the threaded hole.

3. Drop the 1/2" flat washer Gr. 8 over the threaded rod and fasten the nut to the threaded rod. Tighten the nut until the spring bar is raised enough to insert the pin through the pin hole. Center the pin within the hole.

4. Loosen the nut to lower the spring bar. Remove the spring tool assembly by removing the 1/2" cap screw.
5. Remove the spring from the blade by removing the bolt from the bottom of the spring bar.
6. Insert the new spring with the spring bar up through the top anchor on the blade. Fasten the bottom of the spring bar to the anchor on the trip edge with the previously removed fasteners. Tighten.
7. Repeat steps 1 and 2 above.
8. Repeat step 3 above, except remove the pin from the spring bar.
9. Repeat step 4 above.

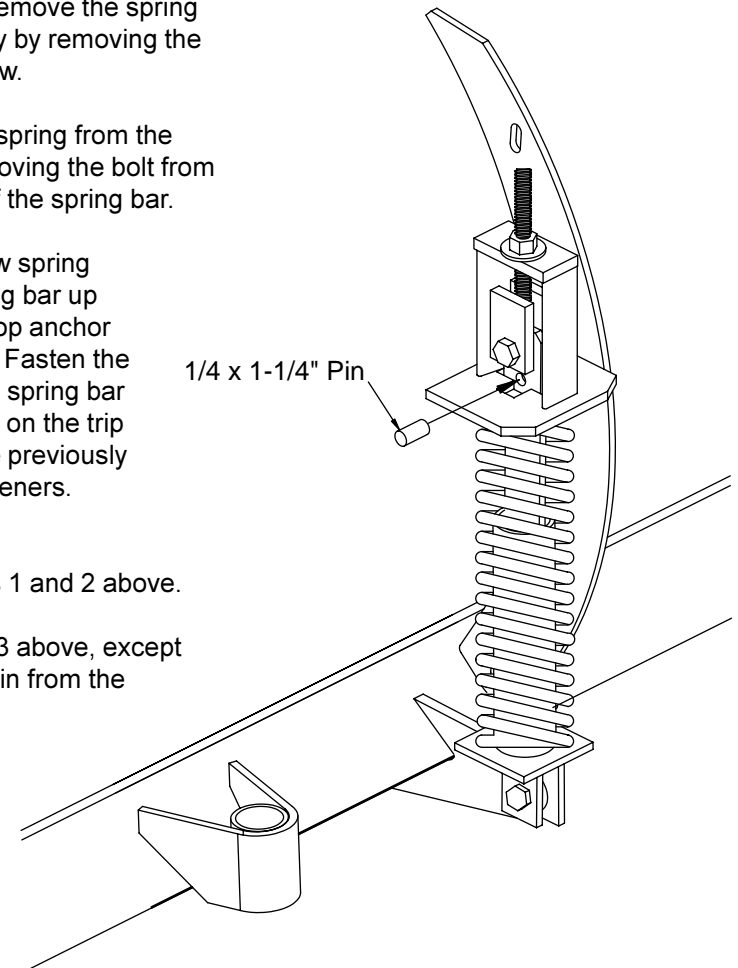
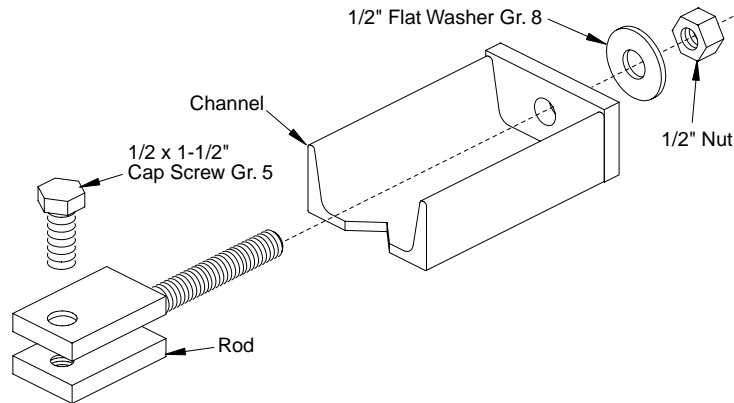





Fisher Engineering  
P.O. Box 529  
Rockland, ME 04841

Copyright © 1997 Douglas Dynamics, L.L.C. All rights reserved. This material may not be reproduced or copied, in whole or in part, in any printed, mechanical, electronic, film or other distribution and storage media, without the written consent of Fisher Engineering. Authorization to photocopy items for internal or personal use by Fisher Engineering outlets is granted.

Fisher Engineering reserves the right under its product improvement policy to change construction or design details and furnish equipment when so altered without reference to illustrations or specifications used herein. Fisher Engineering and the vehicle manufacturer may require and/or recommend optional equipment for snow removal. This product is manufactured under the following patents: 4,280,062, 4,999,935, 5,353,530, and 5,420,480 and other patents pending. Fisher Engineering offers a one-year limited warranty on all snowplows and accessories. See separately printed page for this important information. The following are registered® and unregistered™ trademarks of Douglas Dynamics, L.L.C.: FISHER®, EZ-V™